



Specification for TFT

AFK320480A0-3.5INTH-R-ANO

Revision V01



A	Orient Display
FK	TFT Type
320480	Resolution 320 x 480
A0	Serial A0
3.5	3.5", Module Dimension 54.66 x 82.94 x 8.95mm
I	IPS Display
/	All Viewing Direction
N	Top: -20~+70°C; Tstr: -30~+80°C
T	Transmissive
H	High Brightness, 800cd/m2
R	Resistive Touch Panel
/	Controller HX8357D
ANO	4W-SPI Interface + compatible Arduino



CONTENTS

1. Display Characteristics	3
2. Pin Assignments	3
3. Absolute Maximum Ratings	3
4. Electrical Characteristics	4
5. Backlight Characteristics	4
6. Optical Specifications	4
7. AC Characteristics	7
8. Reliability Test Conditions	9
9. Handling Precautions	10
10. Specification of Quality Assurance	11
11. Mechanical Drawing	19

Version	Date	Description
V01	2025-9-19	First issue

1. Display Characteristics

Item	Specification	Unit	Note
LCD Size	3.5"	inch	
Panel Type	IPS	-	
Resolution	320(RGB)*480	pixel	
Display Mode	TRANSMISSIVE,NORMALLY BLACK	-	
Display Number of Colors	262K	-	
Viewing Direction	Free	-	Note1
Module Size	54.66(W)x82.94(H)x8.95Max(D)	mm	Note1
Weight	TBD	g	
Driver IC	HX8357D or compatible	-	
Touch Panel	With RTP		
Interface	4W-SPI	-	

Note 1: Please refer to the mechanical drawing.

2. Pin Assignments

Pin No.	Symbol	I/O	Function	Note
1	GND	POWER	Ground	
2	VDD	I/O	Supply Voltage	
3	SCL	I/O	This pin is used serial interface clock	
4	SDA	I/O	Serial in/out signal in 4-wire 8-bit serial data interface	
5	RST	I/O	This signal will reset the device and it must be applied to properly initialize the chip	
6	DC	I/O	Serves as command or parameter select	
7	CS	I/O	Chip selection pin	
8	BLK	I/O	Back light control pin, PWM can be connected to it	
9	YU	Analog	RTP Top electrode-differential analog	
10	XL	Analog	RTP Left electrode-differential analog	
11	YD	Analog	RTP Bottom electrode-differential analog	
12	XR	Analog	RTP Right electrode-differential analog	
13	TP-PENIRO	I/O	RTP IC pen touches the interrupt pin	
14	TP-I2C-SCL	I/O	RTP IC serial clock	
15	TP-I2C-SDA	I/O	RTP IC serial data	
16	TP-I2C-A0	I/O	RTP IC Address input	

3. Absolute Maximum Ratings

Item	Symbol	Min	Max	Unit
Power supply	P+	-0.3	4.6	V
Operation temperature	Top	-20	70	°C
Storage temperature	Tst	-30	80	°C

4. Electrical Characteristics

DC CHARACTERISTICS (at Ta=25°C)

Item	Symbol	Values			Unit	Note
		Min.	Typ.	Max.		
Logic Supply Voltage	VDD	2.5	3.3	3.6	V	
Input Logic High Voltage	VIH	0.7VDD	-	VDD	V	
Input Logic Low Voltage	VIL	0	-	0.3VDD	V	
Output Logic High Voltage	VOH	0.8VDD	-	VDD	V	
Output Logic Low Voltage	VOL	0	-	0.2VDD	V	

5. Backlight Characteristics

(at Ta=25°C, RH=60%)

Item	Symbol	Min.	Typ.	Max.	Unit	Note
LED forward voltage	VF	17.1	19.2	19.8	V	IF=20*2mA
LED forward current	IF	--	40	--	mA	
LED power consumption	PLED	--	768	--	mW	Note1
Uniformity	--	70	--	---	%	IF=20*2mA
Connection mode	--	6series * 2parallel			/	
LED life-time	--	--	30000	--	Hrs	Note2

Note1. Calculator Value for reference: $IF * VF = PLED$

Note2. The LED Life-time define as the estimated time to 50% degradation of initial brightness at Ta=25°C and IF=40mA. The LED lifetime could be decreased if operating IF is larger than 40mA

6. Optical Specifications

ITEM	SYMBOL	CONDITIONS	SPECIFICATIONS			UNIT	NOTE
			MIN	TYP.	MAX		
Luminance	L	IL =40mA	640	800	1120	Cd/m ²	
Contrast Ratio	CR	θ=0°		700			
Response Time	TON	25°C		30		ms	
	TOFF						
CIE Color Coordinate	Red	XR	0.6221	0.6621	0.7021		
		YR	0.2845	0.3245	0.3645		
	Green	XG	0.2814	0.3214	0.3614		
		YG	0.5759	0.6159	0.6559		
	Blue	XB	0.0887	0.1287	0.1687		

	Whit e	YB		0.0139	0.0539	0.0939		
		XW		0.2660	0.3060	0.3460		
		YW		0.3024	0.3424	0.3824		
Viewing Angle	Hor.	θ_{x+}	CR \geq 10		80		Degree	
		θ_{x-}			80			
	Ver.	θ_{y+}			80			
		θ_{y-}			80			
Uniformity	Un			80			%	

Note 1: Definition of Viewing Angle θ_x and θ_y :

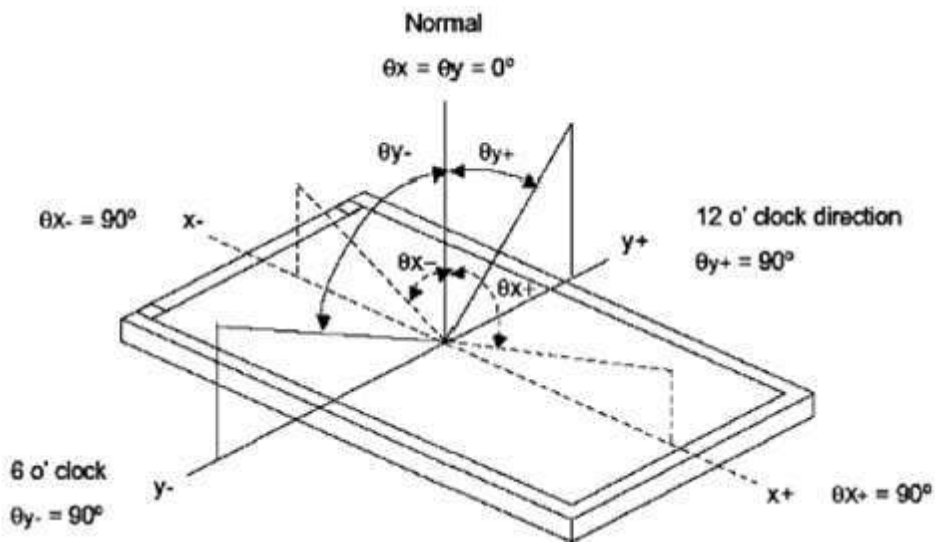

Note 2: Definition of contrast ratio CR:

$$CR = \frac{\text{Luminance of white state}}{\text{Luminance of black state}}$$

Note 3: Definition of Response Time (T_r , T_f)

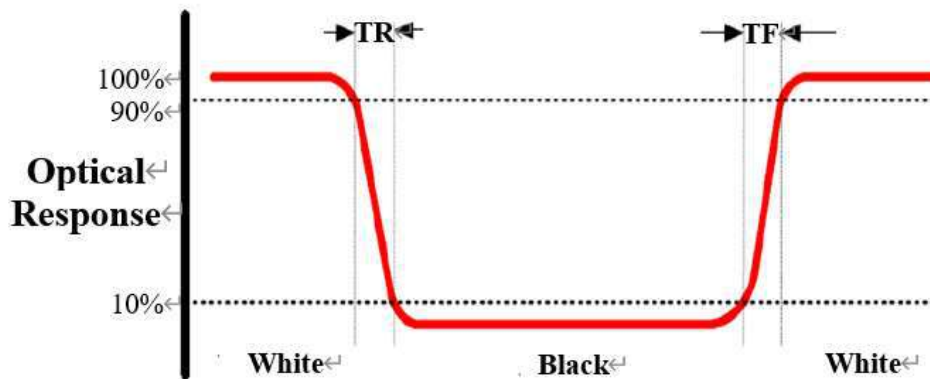

Note 4: Definition of Luminance

① The Brightness Test Equipment Setup

Field=2° (As measuring "black" image, field=2° is the best testing condition)

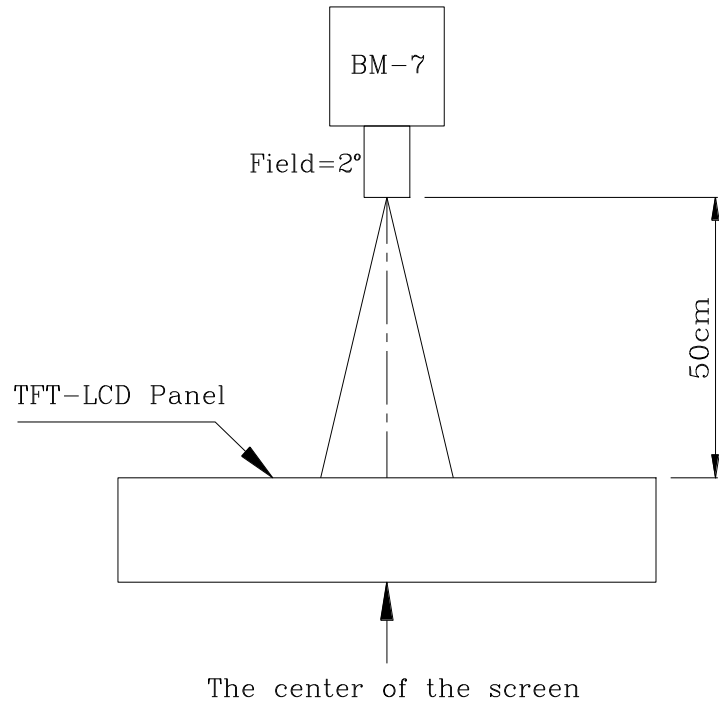

② The Brightness Test Point Setup

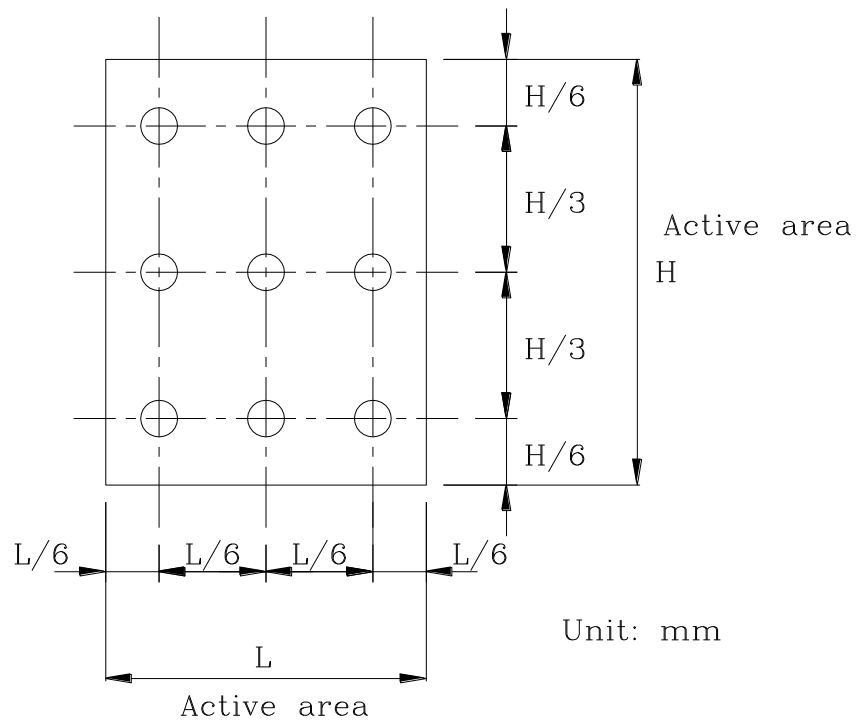

7. AC Characteristics

Refer to IC datasheet

7.1 4-line SPI interface characteristics

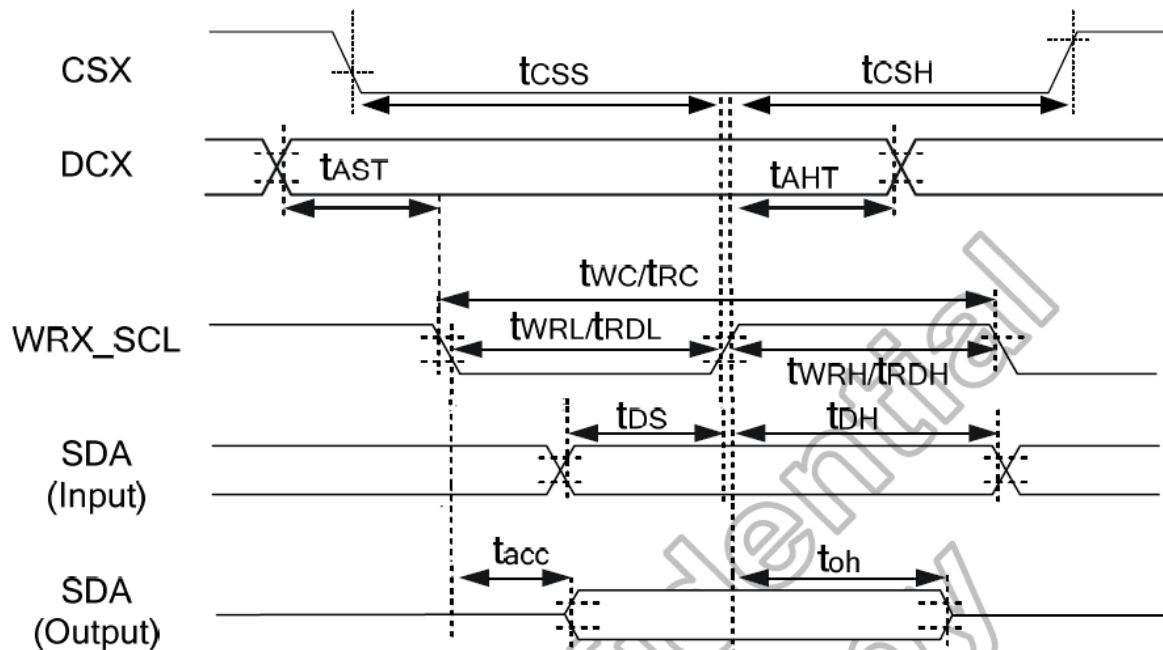

Figure 7.2: SPI interface characteristics

(GND=0V, IOVCC=1.8V, VCI=2.8V, TA=25°C, Sleep Out states)

Signal	Symbol	Parameter	Min.	Max.	Unit	Description
CSX	t_{css}	Chip select setup time (Write)	15	-	ns	-
	t_{css}	Chip select setup time (Read)	60	-		
	t_{csh}	Chip select hold time (Write)	15	-		
	t_{csh}	Chip select hold time (Read)	65	-		
DCX	t_{AST}	Address setup time	0	-	ns	-
	I	Address hold time (Write/Read)	10	-		
WRX_SCL (Write)	t_{wc}	Write cycle	66	-	ns	-
	t_{wrh}	Control pulse "H" duration	15	-		
	t_{wrl}	Control pulse "L" duration	15	-		
WRX_SCL (Read)	t_{rc}	Read cycle	150	-	ns	-
	t_{rdh}	Control pulse "H" duration	60	-		
	t_{rdl}	Control pulse "L" duration	60	-		
SDA (Input)	t_{ds}	Data setup time	10	-	ns	For maximum $C_L=30\text{pF}$ For minimum $C_L=8\text{pF}$
	t_{dh}	Data hold time	10	-		
SDA (Output)	t_{acc}	Read access time	10	50	ns	
	t_{oh}	Output disable time	15	50		

Table 7.2: SPI interface characteristics

Note: The input signal rise time and fall time (t_r , t_f) is specified at 15 ns or less. Logic high and low levels are specified as 30% and 70% of IOVCC for Input signals.

7.2 SPI Data mode

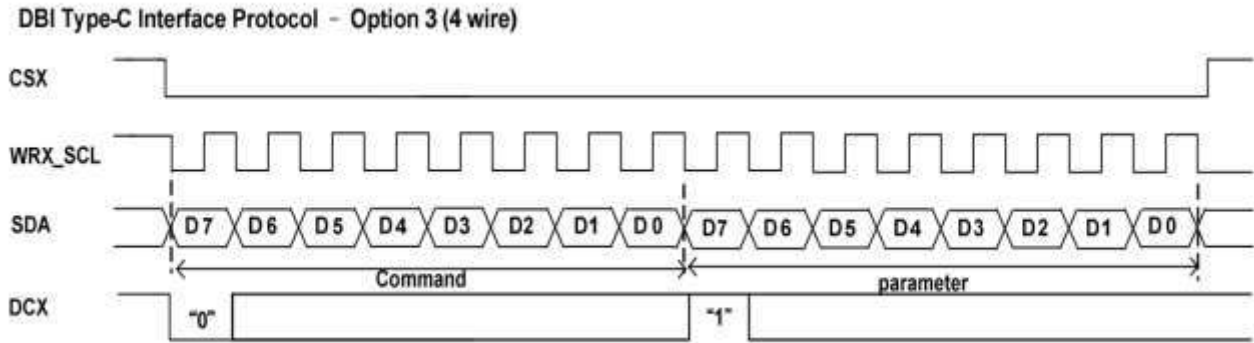

7.3 Reset input timing

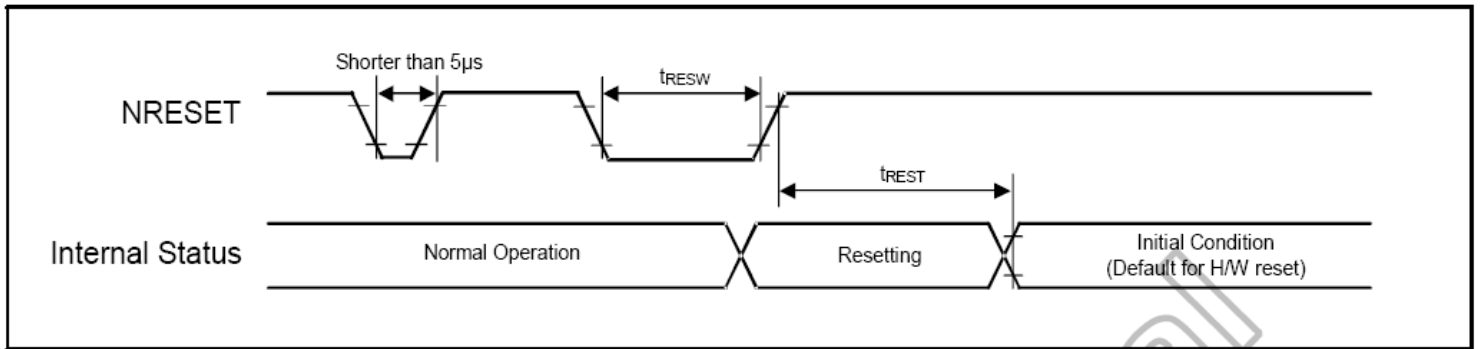

Figure 7.5: Reset input timing

Symbol	Parameter	Related Pins	Spec.			Note	Unit
			Min.	Typ.	Max.		
tRESW	Reset low pulse width ⁽¹⁾	NRESET	10	-	-	-	µs
tREST	Reset complete time ⁽²⁾	-	5	-	-	When reset applied during SLPIN mode	ms
		-	120	-	-	When reset applied during SLPOUT mode	ms

Table 7.5: Reset input timing

Note: (1) Spike due to an electrostatic discharge on NRESET line does not cause irregular system reset according to the following table.

NRESET Pulse	Action
Shorter than 5 μ s	Reset Rejected
Longer than 10 μ s	Reset
Between 5 μ s and 10 μ s	Reset Start

- (2) During the resetting period, the display will be blanked (The display is entering blanking sequence, which Maximum time is 120 ms, when Reset Starts in Sleep Out –mode. The display remains the blank state in Sleep In –mode) and then return to Default condition for H/W reset.
- (3) During Reset Complete Time, ID and VCOM value in OTP will be latched to internal register during this period. This loading is done every time when there is H/W reset complete time (tREST) within 5ms after a rising edge of NRESET.
- (4) Spike Rejection also applies during a valid reset pulse as shown as below:

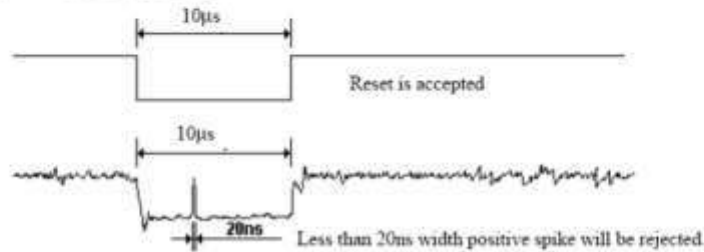

01. It is necessary to wait 5msec after releasing NRESET before sending commands. Also Sleep Out command cannot be sent for 120msec.

8. Reliability Test Conditions

8.1 Standard Specification for Reliability of LCD Module

No	Test Item	Condition	Remarks
1	High Temperature Operation	Ts = +70°C, 240 hours	IEC60068-21:2007 GB2423.2-2008
2	Low Temperature Operation	Ta = -20°C, 240 hours	IEC60068-2-1:2007 GB/2423.1-2008
3	High Temperature Storage	Ta = +80°C, 240 hours	IEC60068-21:2007 GB/2423.2-2008
4	Low Temperature Storage	Ta = -30°C, 240 hours	IEC60068-21:2007 GB/2423.1-2008
5	Storage at High Temperature and Humidity	Ta = +60°C, 90% RH max,240hours	IEC60068-2-78 :2001 GB/T2423.3—2006
6	Thermal Shock (non-operation)	-20°C 30 min~+60°C30 min, Change time:5min, 20 Cycle	Start with cold temperature, End with high temperature, IEC60068-214:1984, GB/2423.22-2002
7	ESD	C=150pF,R=330 Ω ,5point/panel Air:±8Kv,10times; Contact:±4Kv,10times (Environment:15°C~35°C, 30%~60%.86Kpa~106Kp)	IEC61000-42:2001 GB/T17626.2-2006
8	Package Drop Test	Height:80cm, 1corner,3 edges,6 surfaces	IEC60068-2-32:1990 GB/T2423.8—1995

Note1: Ts is the temperature of panel's surface.

Note2: Ta is the ambient temperature of sample.

8.2 Testing Conditions and Inspection Criteria

For the final test, the testing sample must be stored at room temperature for 24 hours. After the tests listed in Table 8.2, standard specifications for reliability will be executed in order to ensure stability.

No	Item	Test Model	In section Criteria
01	Current Consumption	Refer To Specification	The current consumption should conform to the product specification.
02	Contrast	Refer To Specification	After the tests have been executed, the contrast must be larger than half of its initial value prior to the tests.
03	Appearance	Visual inspection	Defect free.

8.3 MTBF

MTBF	Functions, performance, appearance, etc. shall be free from remarkable deterioration within 50,000 hours under ordinary operating and storage conditions room temperature ($25\pm 5^{\circ}\text{C}$), normal humidity ($50\pm 10\%$ RH), and in area not exposed to direct sun light.
------	---

9. Handling Precautions

9.1 Handling of LCM

- Avoid external shock.
- Don't apply excessive force on the surface.
- Liquid in LCD is hazardous substance, do not lick or swallow. When the liquid is attaching to your hand, skin, cloth, etc., wash it thoroughly and immediately.
- Don't operate it above the absolute maximum rating.
- Don't disassemble the LCM.
- The operators should wear protections whenever he/she comes into contact with the module. Never touch any of the conductive parts such as the LSI pads, the copper leads on the PCB and the interface terminals with any parts of the human body.
- The modules should be kept in antistatic bags or other containers resistant to static for storage.
- The module is coated with a film to protect the display surface, be careful when peeling off this protective film since static electricity may be generated.

9.2 Storage

- Store it in an ambient temperature of $25\pm 10^{\circ}\text{C}$, and in a relative humidity of $50\pm 10\%$ RH. Don't expose to sunlight or fluorescent light.
- Store it in a clean environment, free from dust, active gas, and solvent.
- Store it in anti-static electricity container.
- Store it without any physical load.

9.3 Soldering

- Use only soldering irons with proper grounding and no leakage.

-
- Iron: no higher than $280\pm 10^{\circ}\text{C}$ and less than 3 sec during hand soldering.
 - Rewiring: no more than 2 times.

10. Specification of Quality Assurance

This standard of Quality Assurance confirms to the quality of LCD module products supplied by ODAN.

10.1 Quality Test

Before delivering, the supplier should conduct the following tests to confirm the quality of products.

- Electrical-Optical Characteristics: According to the individual specification to test the product.
- Appearance Characteristics: According to the individual specification to test the product.
- Reliability Characteristics: According to the definition of reliability on the specification for testing products.

10.2 Delivery Test

Before delivering, the supplier should conduct the delivery test.

- Test method: According to MIL-STD105E.General Inspection Level II take a single Time.
- The defects classify of AQL as following:
Major defect: AQL = 0.65
Minor defect: AQL = 1.5
Total defects: AQL = 1.5

10.3 Non-conforming Analysis & Deal With Manners

10.3.1 Non-conforming Analysis

- Purchaser should provide the data detail of non-conforming sample and the non-conforming.
- After receiving the data detail from purchaser, the analysis of non-conforming should be finished within two weeks.
- If the analysis can't be finished on time, supplier must notice purchaser 3 days in advance.

10.3.2 Disposition of non-conforming

- If any product defect be found during assembling, supplier must change the good for every defect after confirmation.
- Both supplier and customer should analyze the reason and discuss the disposition of non-conforming when the reason of nonconforming is not sure.

10.4 Agreement items

Both parties should negotiate together when the following problems happen.

- There is any problem of standard of quality assurance, and both sides should agree that it must be modified.
- There is any argument item which does not record in the standard of quality assurance.
- Any other special problem.

10.5 Standard of The Product Appearance Test

10.5.1 Manner of appearance test

- The test must be under 20W × 2 or 40W fluorescent light, and the distance of view must be at 30±5cm.
- When test the model of transmissive product must add the reflective plate.
- The test direction is base on around 45° of vertical line.
- Temperature: 25±5°C Humidity: 60±10%RH

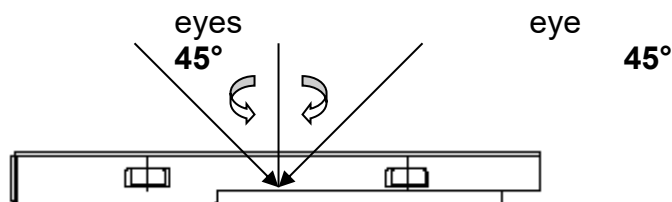

- Definition of area:

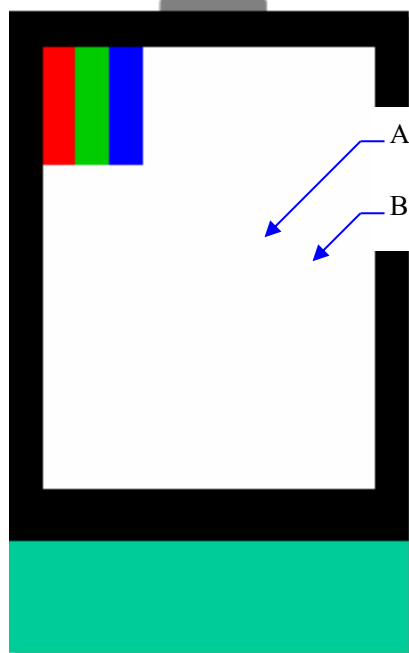

A: Viewing area B: Outside viewing area

10.5.2 Basic principle

- When the standard can not be described, AQL will be applied.
- The sample of the lowest acceptable quality level must be negotiated by both supplier and customer when any dispute happened.
- New item must be added on time when it is necessary.

10.6 Inspection Specification

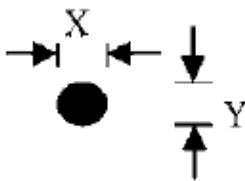
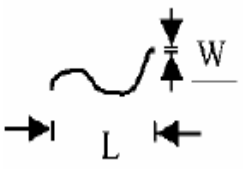
NO.	Item	Criterion	AQL												
01	Electrical Testing	1.1 Missing vertical, horizontal segment, segment contrast defect. 1.2 Missing character, dot or icon. 1.3 Display malfunction. 1.4 No function or no display. 1.5 Current consumption exceeds product specifications. 1.6 LCD viewing angle defect. 1.7 Mixed product types. 1.8 Flicker	0.65												
02	Black or White spots or Bright spots or Color spots on LCD (Display only)	2.1 White and black or color spots on display $\leq 0.25\text{mm}$, no more than Five spots. 2.2 Densely spaced: No more than three spots within 3mm.	1.5												
03	LCD and Touch Panel black spots, white spots, contamination (non – display)	3.1 Round type: As following drawing $\Phi = (X+Y) / 2$  <table border="1" data-bbox="885 892 1404 1165"> <thead> <tr> <th>Size(mm)</th> <th>Acceptable Q'ty</th> </tr> </thead> <tbody> <tr> <td>$\Phi \leq 0.10$</td> <td>Accept no dense</td> </tr> <tr> <td>$0.10 < \Phi \leq 0.20$</td> <td>2</td> </tr> <tr> <td>$0.20 < \Phi \leq 0.25$</td> <td>2</td> </tr> <tr> <td>$0.25 < \Phi \leq 0.30$</td> <td>1</td> </tr> <tr> <td>$0.30 < \Phi$</td> <td>0</td> </tr> </tbody> </table> <p>* Densely spaced: No more than two spots within 3mm.</p>	Size(mm)	Acceptable Q'ty	$\Phi \leq 0.10$	Accept no dense	$0.10 < \Phi \leq 0.20$	2	$0.20 < \Phi \leq 0.25$	2	$0.25 < \Phi \leq 0.30$	1	$0.30 < \Phi$	0	1.5
		Size(mm)	Acceptable Q'ty												
$\Phi \leq 0.10$	Accept no dense														
$0.10 < \Phi \leq 0.20$	2														
$0.20 < \Phi \leq 0.25$	2														
$0.25 < \Phi \leq 0.30$	1														
$0.30 < \Phi$	0														
3.2 Line type: (As following drawing)  <table border="1" data-bbox="787 1291 1404 1564"> <thead> <tr> <th>Length(mm)</th> <th>Width(mm)</th> <th>Acceptable Q'ty</th> </tr> </thead> <tbody> <tr> <td>---</td> <td>$W \leq 0.02$</td> <td>Accept no dense</td> </tr> <tr> <td>$L \leq 3.0$</td> <td>$0.02 < W \leq 0.05$</td> <td rowspan="2">2</td> </tr> <tr> <td>$L \leq 2.5$</td> <td>$0.03 < W \leq 0.08$</td> </tr> <tr> <td>---</td> <td>$0.08 < W$</td> <td>Rejection</td> </tr> </tbody> </table> <p>* Densely spaced: No more than two lines within 3mm.</p>	Length(mm)	Width(mm)	Acceptable Q'ty	---	$W \leq 0.02$	Accept no dense	$L \leq 3.0$	$0.02 < W \leq 0.05$	2	$L \leq 2.5$	$0.03 < W \leq 0.08$	---	$0.08 < W$	Rejection	1.5
Length(mm)	Width(mm)	Acceptable Q'ty													
---	$W \leq 0.02$	Accept no dense													
$L \leq 3.0$	$0.02 < W \leq 0.05$	2													
$L \leq 2.5$	$0.03 < W \leq 0.08$														
---	$0.08 < W$	Rejection													

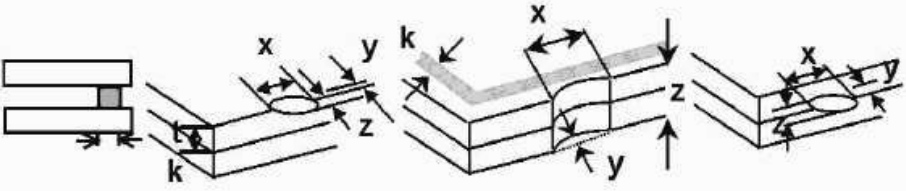
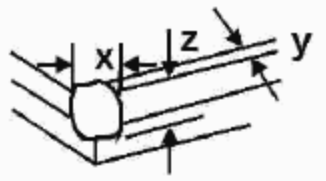
NO.	Item	Criterion	AQL																		
04	Polarizer bubbles	If bubbles are visible, judge using black spot specifications, not easy to find, must check in specify direction	Size Φ (mm)	Acceptable Q'ty	1.5																
			$\Phi \leq 0.20$	Accept no dense																	
			$0.20 < \Phi \leq 0.50$	3																	
			$0.50 < \Phi \leq 1.00$	2																	
			$1.00 < \Phi$	0																	
			Total Q'ty	3																	
05	Scratches	Follow NO.3 -2 Line Type.																			
06	Chipped glass	<p>Symbols: x: Chip length y: Chip width z: Chip thickness k: Seal width t: Glass thickness a: LCD side length L: Electrode pad length</p> <p>6.1 General glass chip: 6.1.1 Chip on panel surface and crack between panels:</p>  <table border="1" data-bbox="479 1108 1291 1297"> <tr> <td>z: Chip thickness</td> <td>y: Chip width</td> <td>x: Chip length</td> </tr> <tr> <td>$Z \leq 1/2t$</td> <td>Not over viewing area</td> <td>$x \leq 1/8a$</td> </tr> <tr> <td>$1/2t < z \leq 2t$</td> <td>Not exceed 1/3k</td> <td>$x \leq 1/8a$</td> </tr> </table> <p>Unit: mm ⊙ If there are 2 or more chips, x is the total length of each chip</p> <p>6.1.2 Corner crack:</p>  <table border="1" data-bbox="479 1621 1291 1810"> <tr> <td>z: Chip thickness</td> <td>y: Chip width</td> <td>x: Chip length</td> </tr> <tr> <td>$Z \leq 1/2t$</td> <td>Not over viewing area</td> <td>$x \leq 1/8a$</td> </tr> <tr> <td>$1/2t < z \leq 2t$</td> <td>Not exceed 1/3k</td> <td>$x \leq 1/8a$</td> </tr> </table> <p>Unit: mm ⊙ If there are 2 or more chips, x is the total length of each chip</p>	z: Chip thickness	y: Chip width	x: Chip length	$Z \leq 1/2t$	Not over viewing area	$x \leq 1/8a$	$1/2t < z \leq 2t$	Not exceed 1/3k	$x \leq 1/8a$	z: Chip thickness	y: Chip width	x: Chip length	$Z \leq 1/2t$	Not over viewing area	$x \leq 1/8a$	$1/2t < z \leq 2t$	Not exceed 1/3k	$x \leq 1/8a$	1.5
		z: Chip thickness	y: Chip width	x: Chip length																	
$Z \leq 1/2t$	Not over viewing area	$x \leq 1/8a$																			
$1/2t < z \leq 2t$	Not exceed 1/3k	$x \leq 1/8a$																			
z: Chip thickness	y: Chip width	x: Chip length																			
$Z \leq 1/2t$	Not over viewing area	$x \leq 1/8a$																			
$1/2t < z \leq 2t$	Not exceed 1/3k	$x \leq 1/8a$																			

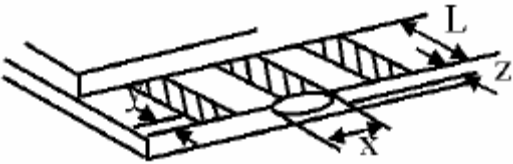
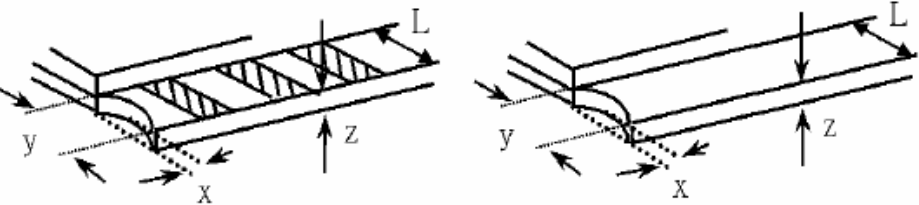
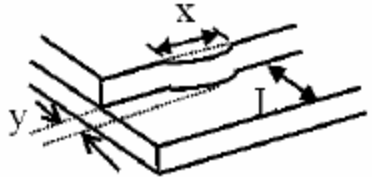
NO.	Item	Criterion	AQL																
07	Glass crack	<p>Symbols: x: Chip length y: Chip width z: Chip thickness k: Seal width t: Glass thickness a: LCD side length L: Electrode pad length</p> <p>7.2 Protrusion over terminal: 7.2.1 Chip on electrode pad:</p>  <table border="1" data-bbox="594 659 1265 808"> <tr> <td>y: Chip width</td> <td>x: Chip length</td> <td>z: Chip thickness</td> </tr> <tr> <td>$y \leq 0.5\text{mm}$</td> <td>$x \leq 1/8a$</td> <td>$0 < z \leq t$</td> </tr> </table> <p>7.2.2 Non-conductive portion:</p>  <table border="1" data-bbox="594 1176 1265 1325"> <tr> <td>y: Chip width</td> <td>x: Chip length</td> <td>z: Chip thickness</td> </tr> <tr> <td>$y \leq L$</td> <td>$x \leq 1/8a$</td> <td>$0 < z \leq t$</td> </tr> </table> <p>⊙ If there chipped area touches the ITO terminal, over 2/3 of the ITO must remain and be inspected according to electrode terminal specifications. ⊙ If the product will be heat sealed by the customer, the alignment mark must not be damaged.</p> <p>7.2.3 Substrate protuberance and internal crack</p>  <table border="1" data-bbox="896 1640 1326 1780"> <tr> <td>y: width</td> <td>x: length</td> </tr> <tr> <td>$y \leq 1/3L$</td> <td>$X \leq a$</td> </tr> </table>	y: Chip width	x: Chip length	z: Chip thickness	$y \leq 0.5\text{mm}$	$x \leq 1/8a$	$0 < z \leq t$	y: Chip width	x: Chip length	z: Chip thickness	$y \leq L$	$x \leq 1/8a$	$0 < z \leq t$	y: width	x: length	$y \leq 1/3L$	$X \leq a$	1.5
y: Chip width	x: Chip length	z: Chip thickness																	
$y \leq 0.5\text{mm}$	$x \leq 1/8a$	$0 < z \leq t$																	
y: Chip width	x: Chip length	z: Chip thickness																	
$y \leq L$	$x \leq 1/8a$	$0 < z \leq t$																	
y: width	x: length																		
$y \leq 1/3L$	$X \leq a$																		

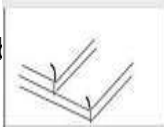
NO.	Item	Criterion	AQL
08	Cracked glass	The LCD with any extensive crack is not acceptable 	1.5
09	Backlight elements	9.1 Illumination source flickers when lit. 9.2 Spots or scratches that appear when lit must be judged. Using LCD spot, lines and contamination standards. 9.3 Backlight doesn't light or color is wrong.	1.5 1.5 0.65
10	Bezel	Bezel must comply with product specifications.	1.5
11	PCB、COB	11.1 COB seal may not have pinholes larger than 0.2mm or contamination. 11.2 COB seal surface may not have pinholes through to the IC. 11.3 The height of the COB should not exceed the height indicated in the assembly diagram. 11.4 There may not be more than 2mm of sealant outside the seal area on PCB. And there should be no more than three places. 11.5 Parts on PCB must be the same as on the production characteristic chart, There should be no wrong parts, missing parts or excess parts. 11.6 The jumper on the PCB should conform to the product characteristic chart.	1.5 1.5 1.5 1.5 0.65 0.65
12	FPC	12.1 FPC terminal damage $\leq 1/2$ FPC terminal width and can not affect the function , we judge accept. 12.2 FPC alignment hole damage $\leq 1/2$ alignment area and can not affect the function , we judge accept.	1.5 1.5
13	Soldering	13.1 No cold solder joints, missing solder connections, oxidation or icicle. 13.2 No short circuits in components on PCB or FPC.	1.5 0.65

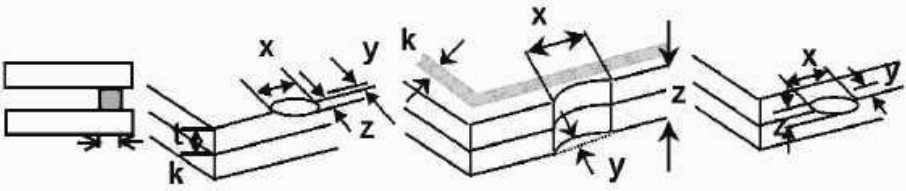
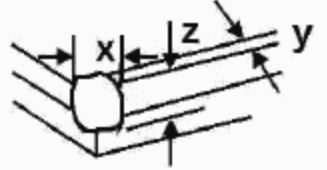
NO.	Item	Criterion	AQL												
14	Touch Panel Chipped glass	<p>Symbols: x: Chip length y: Chip width z: Chip thickness k: Seal width t: Touch Panel Total thickness a: LCD side length L: Electrode pad length</p> <p>14.1 General glass chip: 14.1.1 Chip on panel surface and crack between panels:</p>  <table border="1" data-bbox="446 735 1258 955"> <tr> <td>z: Chip thickness</td> <td>y: Chip width</td> <td>x: Chip length</td> </tr> <tr> <td>$z \leq t$</td> <td>$\leq 1/2 k$ and not over viewing area</td> <td>$x \leq 1/8a$</td> </tr> </table> <p>⊙ Unit: mm ⊙ If there are 2 or more chips, x is the total length of each chip</p> <p>14.1.2 Corner crack:</p>  <table border="1" data-bbox="446 1323 1258 1543"> <tr> <td>z: Chip thickness</td> <td>y: Chip width</td> <td>x: Chip length</td> </tr> <tr> <td>$z \leq t$</td> <td>$\leq 1/2 k$ and not over viewing area</td> <td>$x \leq 1/8a$</td> </tr> </table> <p>⊙ Unit: mm ⊙ If there are 2 or more chips, x is the total length of each chip</p>	z: Chip thickness	y: Chip width	x: Chip length	$z \leq t$	$\leq 1/2 k$ and not over viewing area	$x \leq 1/8a$	z: Chip thickness	y: Chip width	x: Chip length	$z \leq t$	$\leq 1/2 k$ and not over viewing area	$x \leq 1/8a$	1.5
z: Chip thickness	y: Chip width	x: Chip length													
$z \leq t$	$\leq 1/2 k$ and not over viewing area	$x \leq 1/8a$													
z: Chip thickness	y: Chip width	x: Chip length													
$z \leq t$	$\leq 1/2 k$ and not over viewing area	$x \leq 1/8a$													

NO.	Item	Criterion	AQL
-----	------	-----------	-----

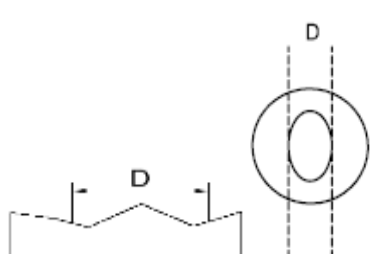
15	Touch Panel(Fish eye、dent and bubble on film)	<table border="1"> <thead> <tr> <th>SIZE(mm)</th> <th>Acceptable Q'ty</th> </tr> </thead> <tbody> <tr> <td>$\Phi \leq 0.2$</td> <td>Accept no dense</td> </tr> <tr> <td>$0.2 < D \leq 0.4$</td> <td>5</td> </tr> <tr> <td>$0.4 < D \leq 0.5$</td> <td>2</td> </tr> <tr> <td>$0.5 < D$</td> <td>0</td> </tr> </tbody> </table>	SIZE(mm)	Acceptable Q'ty	$\Phi \leq 0.2$	Accept no dense	$0.2 < D \leq 0.4$	5	$0.4 < D \leq 0.5$	2	$0.5 < D$	0		1.5
		SIZE(mm)	Acceptable Q'ty											
		$\Phi \leq 0.2$	Accept no dense											
		$0.2 < D \leq 0.4$	5											
		$0.4 < D \leq 0.5$	2											
$0.5 < D$	0													
16	Touch Panel Newton ring	Newton ring dimension $\leq 1/2$ touch panel area and not affect font and line distortion($\leq 2.5\%$) , it is acceptable.	1.5											
17	Touch Panel Linearity	Less than 2.5% is acceptable.	1.5											
18	LCD Ripple	Touch the touch panel , can not see the LCD ripple. Pen: R 1.0mm silicon rubber. Operation Force: 80g	1.5											
19	General appearance	19.1 Pin type must match type in specification sheet.	0.65											
		19.2 LCD pin loose or missing pins.	0.65											
		19.3 Product packaging must the same as specified on packaging specification sheet.	0.65											
		19.4 Product dimension and structure must conform to product specification sheet.	0.65											

11. Mechanical Drawing

