



ORIENT DISPLAY

Your Total LCD Solution Provider

Specification for E-Paper

AES152296A00-2.66ENRS

Revision 1.0



A	Orient Display
ES	E-Paper
152296	Resolution 152 x 296
A00	Revision A00
2.66	Diagonal: 2.66", Module: 36.30×71.82×1.0mm
E	EPD - Electrophoretic Display (Active Matrix)
N	Top: 0~ +50°C; Tstr: -25~+70°C
R	Reflective Polarizer
S	3-/4-wire SPI Interface
/	Controller UC8151 Or Compatible
/	ZIF FPC
/	Ultra Wide Viewing Angle
/	Ultra Low Power Consumption



REVISION HISTORY

Rev	Date	Item	Page	Remark
1.0	SEP.19.2019	New Creation	ALL	

LIST

1. Overview-----	(4)
2. Features-----	(4)
3. Mechanical Specifications-----	(4)
4. Mechanical Drawing of EPD module-----	(5)
5. Input /Output Pin Assignment-----	(6-7)
6. Electrical Characteristics-----	(7)
6.1 Absolute Maximum Rating-----	(7)
6.2 Panel DC Characteristics-----	(8)
6.3 Panel AC Characteristics-----	(9)
6.3.1 MCU Interface Selection -----	(9)
6.3.2 MCU Serial Interface(4-wire SPI) -----	(9-10)
6.3.3 MCU Serial Interface(3-wire SPI) -----	(11)
7. Command Table -----	(12-13)
8. Optical Specifications -----	(14)
9. Handling, Safety and Environment Requirements -----	(14)
10. Reliability test-----	(15)
11. Block Diagram-----	(16)
12. Typical Application Circuit -----	(17)
13. Part Number Definition-----	(18)
14. Inspection condition-----	(18)
14.1 Environment-----	(18)
14.2 Illuminance-----	(18)
14.3 Inspect method-----	(18)
14.4 Display area-----	(19)
14.5 Inspection standard-----	(19)
14.5.1 Electric inspection standard-----	(19)
14.5.2 Appearance inspection standard-----	(20-21)
15. Packaging-----	(21)

1. Overview

AES152296A00-2.66ENRS is an Active Matrix Electrophoretic Display (AM EPD), with interface and a reference system design. The display is capable to display images at 1-bit white, black full display capabilities. The 2.66 inch active area contains 152×296 pixels. The module is a TFT-array driving electrophoresis display, with integrated circuits including gate driver, source driver, MCU interface, timing controller, oscillator, DC-DC, SRAM, LUT, VCOM. Module can be used in portable electronic devices, such as Electronic Shelf Label (ESL) System.

2. Features

- 152×296 pixels display
- High contrast High reflectance
- Ultra wide viewing angle Ultra low power consumption
- Pure reflective mode
- Bi-stable display
- Commercial temperature range
- Landscape portrait modes
- Hard-coat antiglare display surface
- Ultra Low current deep sleep mode
- On chip display RAM
- Waveform can stored in On-chip OTP or written by MCU
- Serial peripheral interface available
- On-chip oscillator
- On-chip booster and regulator control for generating VCOM, Gate and Source driving voltage
- I²C signal master interface to read external temperature sensor
- Support partial update mode
- Built-in temperature sensor

3. Mechanical Specifications

Parameter	Specifications	Unit	Remark
Screen Size	2.66	Inch	
Display Resolution	152(H)×296(V)	Pixel	Dpi:125
Active Area	30.704×60.088	mm	
Pixel Pitch	0.202×0.203	mm	
Pixel Configuration	Rectangle		
Outline Dimension	36.30(H)×71.82(V) ×1.0(D)	mm	
Weight	4.7±0.5	g	

4. Mechanical Drawing of EPD module

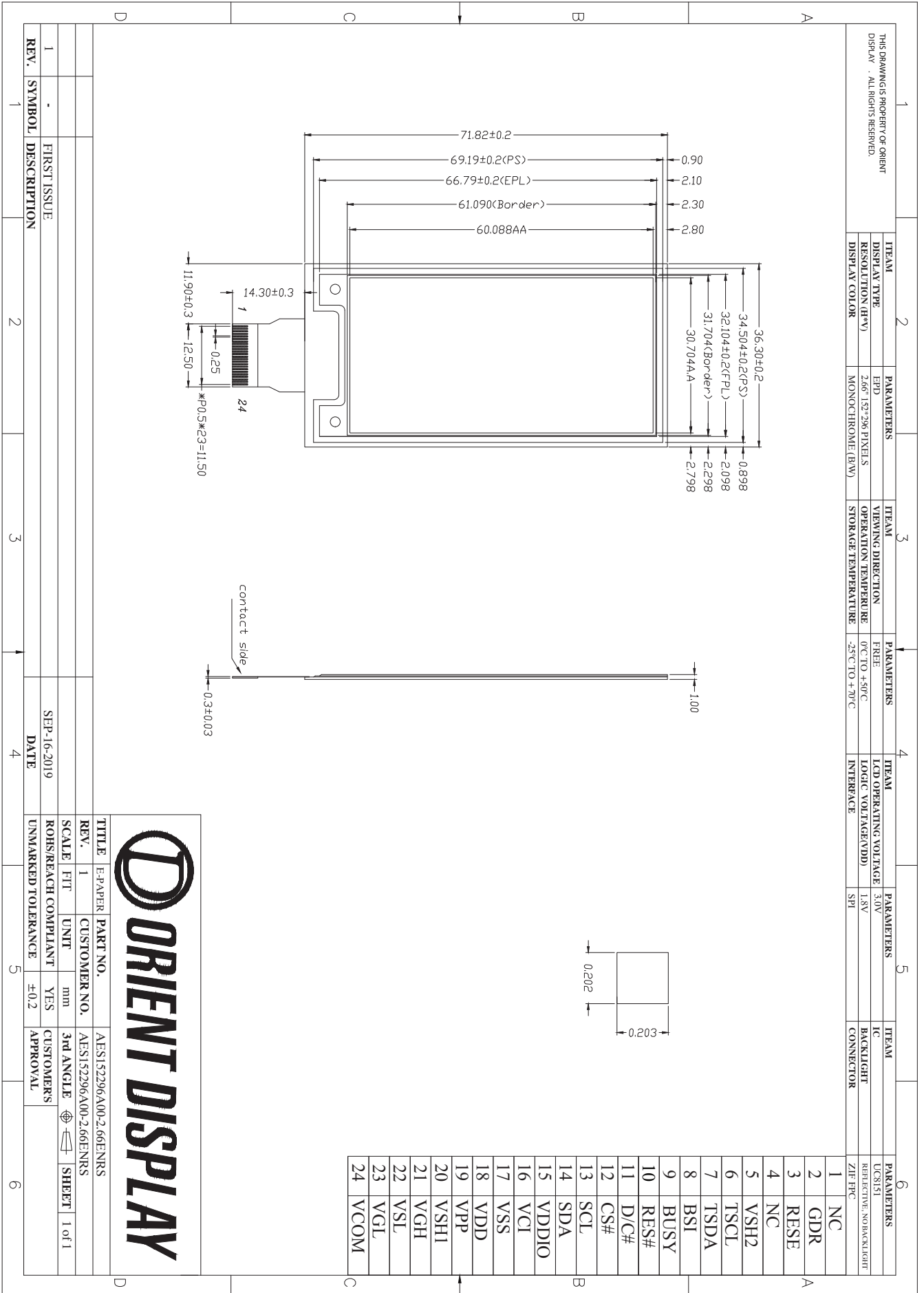

5. Input /Output Pin Assignment

No.	Name	I/O	Description	Remark
1	NC		Do not connect with other NC pins	Keep Open
2	GDR	O	N-Channel MOSFET Gate Drive Control	
3	RESE	I	Current Sense Input for the Control Loop	
4	NC	NC	Do not connect with other NC pins	Keep Open
5	VSH2	C	Positive Source driving voltage	
6	TSCL	O	I2C Interface to digital temperature sensor Clock pin	
7	TSDA	I/O	I2C Interface to digital temperature sensor Data pin	
8	BS1	I	Bus Interface selection pin	Note 5-5
9	BUSY	O	Busy state output pin	Note 5-4
10	RES#	I	Reset signal input. Active Low.	Note 5-3
11	D/C#	I	Data /Command control pin	Note 5-2
12	CS#	I	Chip select input pin	Note 5-1
13	SCL	I	Serial Clock pin (SPI)	
14	SDA	I	Serial Data pin (SPI)	
15	VDDIO	P	Power Supply for interface logic pins It should be connected with VCI	
16	VCI	P	Power Supply for the chip	
17	VSS	P	Ground	
18	VDD	C	Core logic power pin VDD can be regulated internally from VCI. A capacitor should be connected between VDD and VSS	
19	VPP	P	FOR TEST	Keep Open
20	VSH1	C	Positive Source driving voltage	
21	VGH	C	Power Supply pin for Positive Gate driving voltage and VSH1	
22	VSL	C	Negative Source driving voltage	
23	VGL	C	Power Supply pin for Negative Gate driving voltage VCOM and VSL	
24	VCOM	C	VCOM driving voltage	

I = Input Pin, O =Output Pin, /O = Bi-directional Pin (Input/output), P = Power Pin, C = Capacitor Pin

Note 5-1: This pin (CS#) is the chip select input connecting to the MCU. The chip is enabled for MCU communication only when CS# is pulled LOW.

Note 5-2: This pin is (D/C#) Data/Command control pin connecting to the MCU in 4-wire SPI mode. When the pin is pulled HIGH, the data at SDA will be interpreted as data. When the pin is pulled LOW, the data at SDA will be interpreted as command.

Note 5-3: This pin (RES#) is reset signal input. The Reset is active low.

Note 5-4: This pin is Busy state output pin. When Busy is High, the operation of chip should not be interrupted, command should not be sent. The chip would put Busy pin High when -Outputting display waveform -Communicating with digital temperature sensor

Note 5-5: Bus interface selection pin

BS1 State	MCU Interface
L	4-lines serial peripheral interface(SPI) - 8 bits SPI
H	3- lines serial peripheral interface(SPI) - 9 bits SPI

6. Electrical Characteristics

6.1 Absolute Maximum Rating

Parameter	Symbol	Rating	Unit
Logic supply voltage	VCI	-0.3 to +6.0	V
Digital input range	VIN	-0.3 to VCI +0.3	V
Operating Temp range	TOPR	0 to +50	°C.
Storage Temp range	TSTG	-25 to+70	°C.
Optimal Storage Temp	TSTGo	23±2	°C.
Optimal Storage Humidity	HSTGo	55±10	%RH

Note: If ICs are stressed beyond those listed above “absolute maximum ratings”, they may be permanently destroyed. These are stress ratings only, and functional operation of the device at these or any other condition beyond those indicated under “recommended operating conditions” is not implied. Exposure to absolute maximum rated conditions for extended periods may affect device reliability.

6.2 Panel DC Characteristics

Parameter	Symbol	Conditions	Min	Typ	Max	Unit
Single ground	V_{SS}			0		V
Logic Supply Voltage	V_{CI}		2.2	3.0	3.7	V
Core logic voltage	V_{DD}		1.7	1.8	1.9	V
High level input voltage	V_{IH}	Digital input pins	$0.7V_{CI}$	-	V_{CI}	V
Low level input voltage	V_{IL}	Digital input pins	0	-	$0.3V_{CI}$	V
High level output voltage	V_{OH}	Digital input pins, $I_{OH}=400\mu A$	$V_{CI}-0.4$	-	-	V
Low level output voltage	V_{OL}	Digital input pins, $I_{OL}=-400\mu A$	0	-	0.4	V
Typical operating current	I_{opr_VCI}	$V_{CI}=3.0V$	-	-	25	mA
Image update time	-	23 °C	-	3	-	sec
Sleep mode current	I_{slp_VCI}	-	-	26	-	uA
Deep sleep mode current mode	I_{dslp_VCI}		-	-	1.1	uA

Notes: 1. The typical power is measured with following transition from horizontal 2 scale pattern to vertical 2 scale pattern.

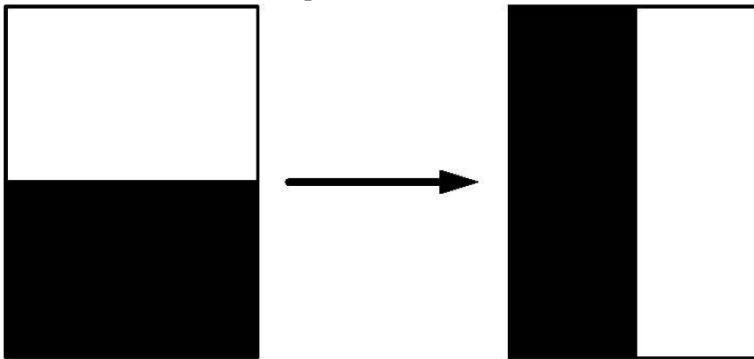

2. The deep sleep power is the consumed power when the panel controller is in deep sleep mode.
3. The listed electrical/optical characteristics are only guaranteed under the controller & waveform provided by ODNA.

6.3 Panel AC Characteristics

6.3.1 MCU Interface Selection

The pin assignment at different interface mode is summarized in Table 6-4-1. Different MCU mode can be set by hardware selection on BS1 pins. The display panel only supports 4-wire SPI or 3-wire SPI interface mode.

Pin Name	Data/Command Interface		Control Signal		
	SDA	SCL	CS#	D/C#	RES#
Bus interface	SDA	SCL	CS#	D/C#	RES#
BS1=L 4-wire SPI	SDA	SCL	CS#	D/C#	RES#
BS1=H 3-wire SPI	SDA	SCL	CS#	L	RES#

6.4.2 MCU Serial Interface (4-wire SPI)

The serial interface consists of serial clock SCL, serial data SDA, D/C#, CS#. This interface supports Write mode and Read mode.

Function	CS#	D/C#	SCL
Write command	L	L	↑
Write data	L	H	↑

Note: ↑ stands for rising edge of signal

In the write mode SDA is shifted into an 8-bit shift register on every rising edge of SCL in the order of D7, D6, ... D0. The level of D/C# should be kept over the whole byte. The data byte in the shift register is written to the Graphic Display Data RAM /Data Byte register or command Byte register according to D/C# pin.

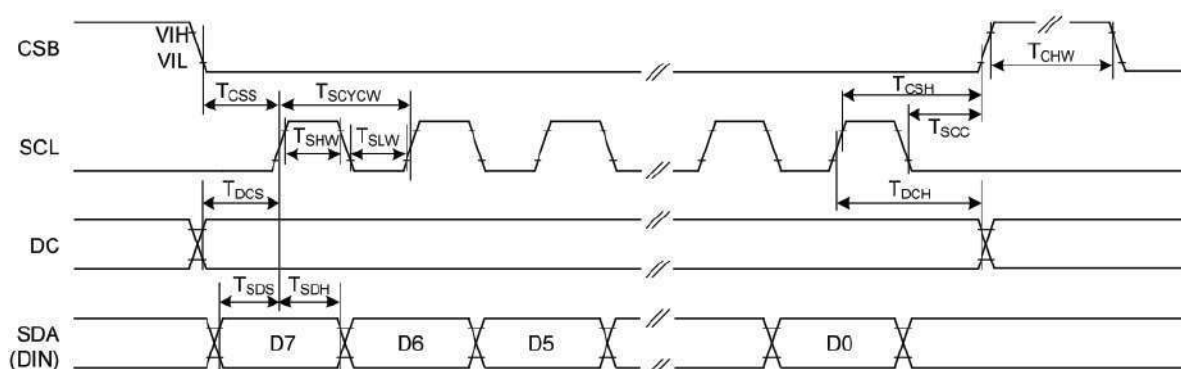

Figure: 4-wire Serial Interface Characteristics (Write mode)

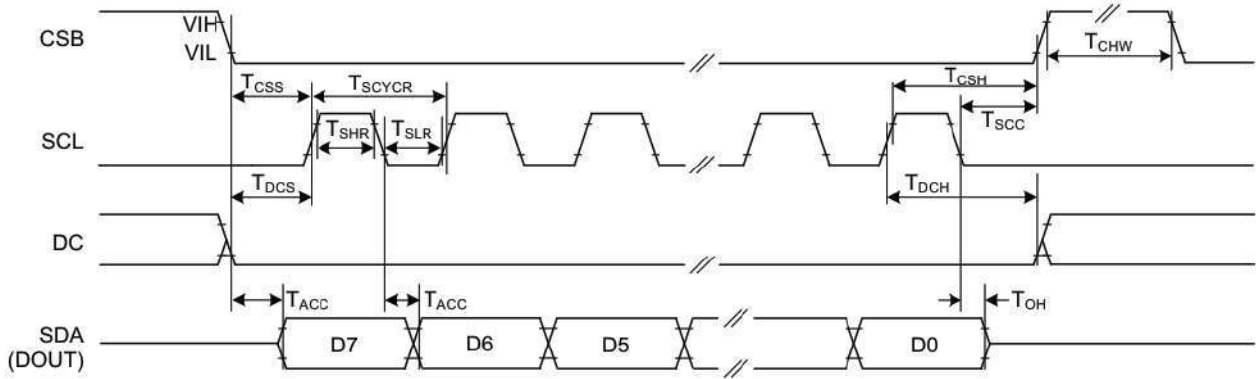

Figure: 4-wire Serial Interface Characteristics (Read mode)

Symbol	Signal / Parameter	Conditions	Min.	Typ.	Max.	Unit
T_{CSS}	CSB	Chip select setup time	60			ns
T_{CSH}		Chip select hold time	65			ns
T_{SCC}		Chip select setup time	20			ns
T_{CHW}		Chip select setup time	40			ns
T_{SCYCW}	SCL	Serial clock cycle (Write)	100			ns
T_{SHW}		SCL "H" pulse width (Write)	35			ns
T_{SLW}		SCL "L" pulse width (Write)	35			ns
T_{SCYCR}		Serial clock cycle (Read)	150			ns
T_{SHR}		SCL "H" pulse width (Read)	60			ns
T_{SLR}		SCL "L" pulse width (Read)	60			ns
T_{DCS}	DC	DC setup time	30			ns
T_{DCH}		DC hold time	30			ns
T_{SDS}	SDA (DIN)	Data setup time	30			ns
T_{SDH}		Data hold time	30			ns
T_{Acc}	SDA	Access time			120	ns
T_{OH}	(DOU)	Output disable time	15			ns

6.3.3 MCU Serial Interface (3-wire SPI)

The 3-wire serial interface consists of serial clock SCL, serial data SDA and CS#. This interface also supports Write mode and Read mode.

The operation is similar to 4-wire serial interface while D/C# pin is not used. There are altogether 9-bits will be shifted into the shift register on every ninth clock in sequence: D/C# bit, D7 to D0 bit. The D/C# bit (first bit of the sequential data) will determine the following data byte in the shift register is written to the Display Data RAM (D/C# bit = 1) or the command register (D/C# bit = 0).

Function	CS#	D/C#	SCL
Write command	L	Tie	↑
Write data	L	Tie	↑

Note: ↑ stands for rising edge of signal

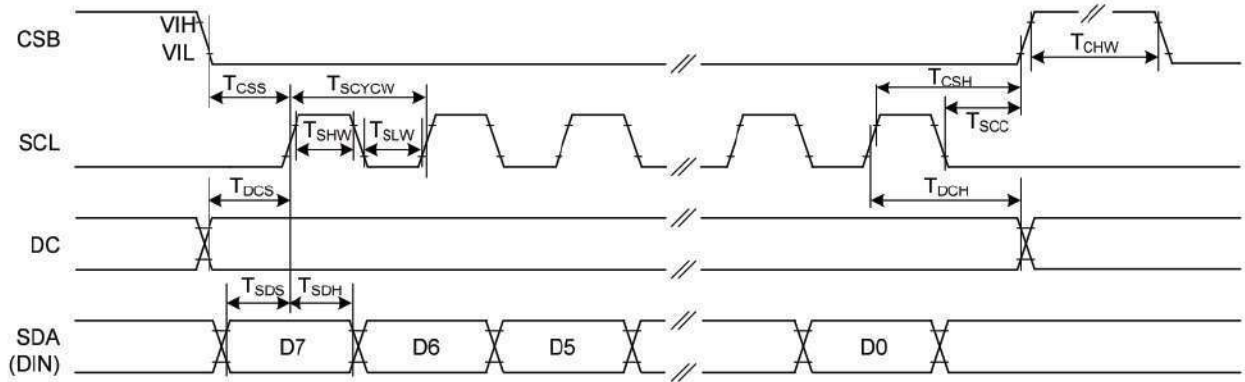

Figure: 4-wire Serial Interface Characteristics (Write mode)

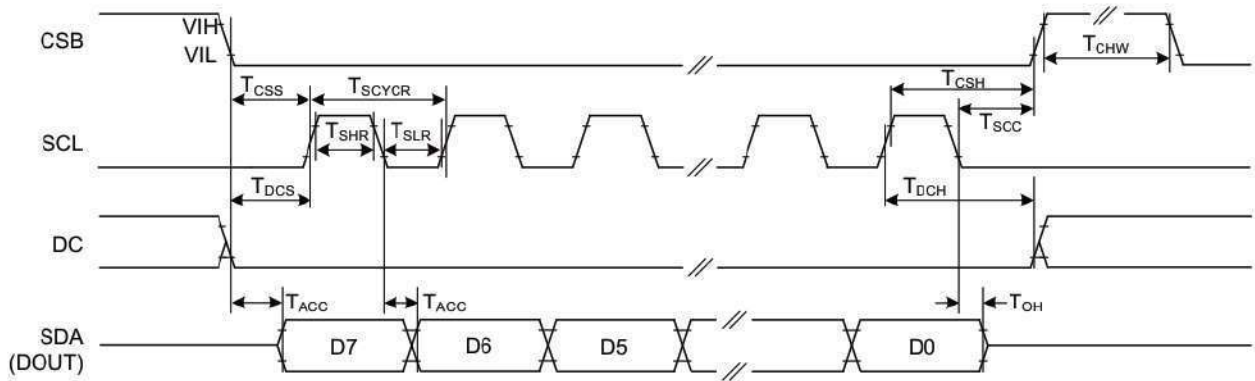

Figure: 4-wire Serial Interface Characteristics (Read mode)

Symbol	Signal / Parameter	Conditions	Min.	Typ.	Max.	Unit
T_{CSS}	CSB	Chip select setup time	60			ns
T_{CSH}		Chip select hold time	65			ns
T_{SCC}		Chip select setup time	20			ns
T_{CHW}		Chip select setup time	40			ns
T_{SCYCW}	SCL	Serial clock cycle (Write)	100			ns
T_{SHW}		SCL "H" pulse width (Write)	35			ns
T_{SLW}		SCL "L" pulse width (Write)	35			ns
T_{SCYCR}		Serial clock cycle (Read)	150			ns
T_{SHR}		SCL "H" pulse width (Read)	60			ns
T_{SLR}		SCL "L" pulse width (Read)	60			ns
T_{DCS}	DC	DC setup time	30			ns
T_{DCH}		DC hold time	30			ns
T_{SDS}	SDA (DIN)	Data setup time	30			ns
T_{SDH}		Data hold time	30			ns
T_{ACC}	SDA (DOUT)	Access time			120	ns
T_{OH}		Output disable time	15			ns

7. Command Table

W/R: 0: Write Cycle 1: Read Cycle

C/D: 0: Command / 1: Data

D7~D0: -: Don't Care #: Valid Data

#	Command	W/R	C/D	D7	D6	D5	D4	D3	D2	D1	D0	Registers	Default	
1	Panel Setting (PSR)	0	0	0	0	0	0	0	0	0	0		00H	
		0	1	#	#	#	#	#	#	#	#	RES[1:0],REG,KW/R,UD,SHL,SHD_N,RST_N	0FH	
2	Power Setting (PWR)	0	0	0	0	0	0	0	0	0	1		01H	
		0	1	--	--	--	--	--	--	#	#	VDS_EN, VDG_EN	03H	
		0	1	--	--	--	--	--	--	#	#	VCOM_HV,VGHL_LV[1:0]	00H	
		0	1	--	--	#	#	#	#	#	#	VDH[5:0]	26H	
		0	1	--	--	#	#	#	#	#	#	VDL[5:0]	26H	
		0	1	--	--	#	#	#	#	#	#	VDHR[5:0]	03H	
3	Power OFF (POF)	0	0	0	0	0	0	0	0	1	0		02H	
4	Power OFF Sequence Setting (PFS)	0	0	0	0	0	0	0	0	1	1		03H	
		0	1	--	--	#	#	--	--	--	--	T_VDS_OF[1:0]	00H	
5	Power ON (PON)	0	0	0	0	0	0	0	1	0	0		04H	
6	Power ON Measure (PMES)	0	0	0	0	0	0	0	1	0	1		05H	
7	Booster Soft Start (BTST)	0	0	0	0	0	0	0	1	1	0		06H	
		0	1	#	#	#	#	#	#	#	#	BT_PHA[7:0]	17H	
		0	1	#	#	#	#	#	#	#	#	BT_PHB[7:0]	17H	
		0	1	--	--	#	#	#	#	#	#	BT_PHC[5:0]	17H	
8	Deep sleep (DSLPL)	0	0	0	0	0	0	0	1	1	1		07H	
		0	1	1	0	1	0	0	1	0	1	Check code	A5H	
9	Display Start Transmission 1 (DTM1, White/Black Data) (x-byte command)	0	0	0	0	0	1	0	0	0	0	B/W or OLD Pixel Data (160x296):	10H	
		0	1	#	#	#	#	#	#	#	#	KPXL[1:8]	00H	
		0	1	:	:	:	:	:	:	:	:	:	:	:
		0	1	#	#	#	#	#	#	#	#	#	KPXL[n-1:n]	00H
10	Data Stop (DSP)	0	0	0	0	0	1	0	0	0	1		11H	
		1	1	#	--	--	--	--	--	--	--	--	00H	
11	Display Refresh (DRF)	0	0	0	0	0	1	0	0	1	0		12H	
12	Display Start transmission 2 (DTM2, Red Data) (x-byte command)	0	0	0	0	0	1	0	0	1	1	Red or NEW Pixel Data (160X296):	13H	
		0	1	#	#	#	#	#	#	#	#	RPXL[1:8]	00H	
		0	1	:	:	:	:	:	:	:	:	:	:	:
		0	1	#	#	#	#	#	#	#	#	#	RPXL[n-1:n]	00H
13	Auto Sequence (AUTO)	0	0	0	0	0	1	0	1	1	1		17H	
		1	1	1	0	1	0	0	1	0	1	Check code	A5H	
14	PLL control (PLL)	0	0	0	0	1	1	0	0	0	0		30H	
		0	1	--	--	#	#	#	#	#	#	M[2:0], N[2:0]	3CH	
15	Temperature Sensor Calibration (TSC)	0	0	0	1	0	0	0	0	0	0		40H	
		1	1	#	#	#	#	#	#	#	#	D[10:3] / TS[7:0]	00H	
		1	1	#	#	#	--	--	--	--	--	D[2:0] / -	00H	
16	Temperature Sensor Selection (TSE)	0	0	0	1	0	0	0	0	0	1		41H	
		0	1	#	--	--	--	#	#	#	#	TSE,TO[3:0]	00H	

#	Command	W/R	C/D	D7	D6	D5	D4	D3	D2	D1	D0	Registers	Default	
17	Temperature Sensor Write (TSW)	0	0	0	1	0	0	0	0	1	0		42H	
		0	1	#	#	#	#	#	#	#	#		WATTR[7:0]	00H
		0	1	#	#	#	#	#	#	#	#		WMSB[7:0]	00H
		0	1	#	#	#	#	#	#	#	#		WLSB[7:0]	00H
18	Temperature Sensor Read (TSR)	0	0	0	1	0	0	0	0	1	1		43H	
		1	1	#	#	#	#	#	#	#	#		RMSB[7:0]	00H
		1	1	#	#	#	#	#	#	#	#		RLSB[7:0]	00H
19	Panel Break Check (PBC)	0	0	0	1	0	0	0	1	0	0		44H	
		1	1	--	--	--	--	--	--	--	#		PSTA	00H
20	VCOM and data interval setting (CDI)	0	0	0	1	0	1	0	0	0	0		50H	
		0	1	#	#	#	#	#	#	#	#		VBD[1:0], DDX[1:0], CDI[3:0]	D7H
21	Lower Power Detection (LPD)	0	0	0	1	0	1	0	0	0	1		51H	
		1	1	--	--	--	--	--	--	--	#		LPD	01H
22	TCON setting (TCON)	0	0	0	1	1	0	0	0	0	0		60H	
		0	1	#	#	#	#	#	#	#	#		S2G[3:0], G2S[3:0]	22H
23	Resolution setting (TRES)	0	0	0	1	1	0	0	0	0	1		61H	
		0	1	#	#	#	#	#	0	0	0		HRES[7:3]	00H
		0	1	--	--	--	--	--	--	--	#		VRES[8:0]	00H
		0	1	#	#	#	#	#	#	#	#			00H
24	Gate/Source Start setting (GSST)	0	0	0	1	1	0	0	1	0	1		65H	
		0	1	#	#	#	#	#	0	0	0		HST[7:3]	00H
		0	1	--	--	--	--	--	--	--	#		VST[8:0]	00H
		0	1	#	#	#	#	#	#	#	#			00H
25	Revision (REV)	0	0	0	1	1	1	0	0	0	0		70H	
		1	1	#	#	#	#	#	#	#	#		LUT_REV[7:0]	FFH
		1	1	--	--	--	--	#	#	#	#		CHIP_REV[3:0]	0EH
26	Get Status (FLG)	0	0	0	1	1	1	0	0	0	1		71H	
		1	1	--	#	#	#	#	#	#	#		PTL_FLAG, I ² C_ERR, I ² C_BUSYN, DATA_FLAG, PON, POF, BUSY_N	13H
27	Auto Measurement VCOM (AMV)	0	0	1	0	0	0	0	0	0	0		80H	
		0	1	--	--	#	#	#	#	#	#		AMVT[1:0], XON, AMVS, AMV, AMVE	10H
28	Read VCOM Value (VV)	0	0	1	0	0	0	0	0	0	1		81H	
		1	1	--	--	#	#	#	#	#	#		VV[5:0]	00H
29	VCOM_DC Setting (VDCS)	0	0	1	0	0	0	0	0	1	0		82H	
		0	1	--	--	#	#	#	#	#	#		VDCS[5:0]	00H
30	Partial Window (PTL)	0	0	1	0	0	1	0	0	0	0		90H	
		0	1	#	#	#	#	#	0	0	0		HRST[7:3]	00H
		0	1	#	#	#	#	#	1	1	1		HRED[7:3]	07H
		0	1	--	--	--	--	--	--	--	#		VRST[8:0]	00H
		0	1	#	#	#	#	#	#	#	#			00H
		0	1	--	--	--	--	--	--	--	#		VRED[8:0]	00H
		0	1	#	#	#	#	#	#	#	#			00H
		0	1	--	--	--	--	--	--	--	#		PT_SCAN	01H
31	Partial In (PTIN)	0	0	1	0	0	1	0	0	0	1		91H	
32	Partial Out (PTOUT)	0	0	1	0	0	1	0	0	1	0		92H	
33	Program Mode (PGM)	0	0	1	0	1	0	0	0	0	0		A0H	
34	Active Programming (APG)	0	0	1	0	1	0	0	0	0	1		A1H	

- Note:** (1) All other register addresses are invalid or reserved by UltraChip, and should NOT be used.
- (2) Any bits shown here as 0 must be written with a 0. All unused bits should also be set to zero. Device malfunction may occur if this is not done.
- (3) Commands are processed on the 'stop' condition of the interface.
- (4) Registers marked 'W/R' can be read, but the contents are written when the SPI command completes – so the contents can be read and altered. The user can subsequently write the register to restore the contents following an SPI read.

8. Optical Specifications

Measurements are made with that the illumination is under an angle of 45 degree, the detection is perpendicular unless otherwise specified

Symbol	Parameter	Conditions	Min	Typ.	Max	Units	Notes
R	White Reflectivity	White	30	35	-	%	8-1
CR	Contrast Ratio	indoor	8:1		-		8-2
Gn	2Grey Level	-	-	$DS+(WS-DS)*n(m-1)$			8-3
T update	Image update time	at 23 °C	-	3	-	sec	
Life		Topr		1000000times or 5years			

Notes: 8-1. Luminance meter: Eye-One Pro Spectrophotometer.

8-2. CR=Surface Reflectance with all white pixel/Surface Reflectance with all black pixels.

8-3 WS: White state, DS: Dark state

9. Handling, Safety and Environment Requirements

Warning

The display glass may break when it is dropped or bumped on a hard surface. Handle with care. Should the display break, do not touch the electrophoretic material. In case of contact with electrophoretic material, wash with water and soap.

Caution

The display module should not be exposed to harmful gases, such as acid and alkali gases, which corrode electronic components. Disassembling the display module.

Disassembling the display module can cause permanent damage and invalidates the warranty agreements.

Observe general precautions that are common to handling delicate electronic components. The glass can break and front surfaces can easily be damaged. Moreover the display is sensitive to static electricity and other rough environmental conditions.

Data sheet status	
Product specification	This data sheet contains final product specifications.
Limiting values	
Limiting values given are in accordance with the Absolute Maximum Rating System (IEC 134). Stress above one or more of the limiting values may cause permanent damage to the device. These are stress ratings only and operation of the device at these or at any other conditions above those given in the Characteristics sections of the specification is not implied. Exposure to limiting values for extended periods may affect device reliability.	
Application information	
Where application information is given, it is advisory and does not form part of the specification.	

10. Reliability test

NO	Test items	Test condition
1	Low-Temperature Storage	T = -25°C, 240 h Test in white pattern
2	High-Temperature Storage	T = +70°C, RH=40% ,240h Test in white pattern
3	High-Temperature Operation	T = +50°C, RH = 30% ,240h
4	Low-Temperature Operation	0°C, 240h
5	High-Temperature, High-Humidity Operation	T=+40°C, RH=90%,168h
6	High Temperature, High Humidity Storage	T=+60°C, RH=80%,240h Test in white pattern
7	Temperature Cycle	1 cycle:[-25°C 30min]→[+70 °C 30 min] : 100 cycles Test in white pattern
8	UV exposure Resistance	765W/m ² for 168hrs,40 °C Test in white pattern
9	ESD Gun	Air+/-15KV;Contact+/-8KV (Test finished product shell,not display only) Air+/-8KV;Contact+/-6KV (Naked EPD display,no including IC and FPC area) Air+/-4KV;Contact+/-2KV (Naked EPD display,including IC and FPC area)

Note: Put in normal temperature for 1hour after test finished, display performance is ok.

11. Block Diagram

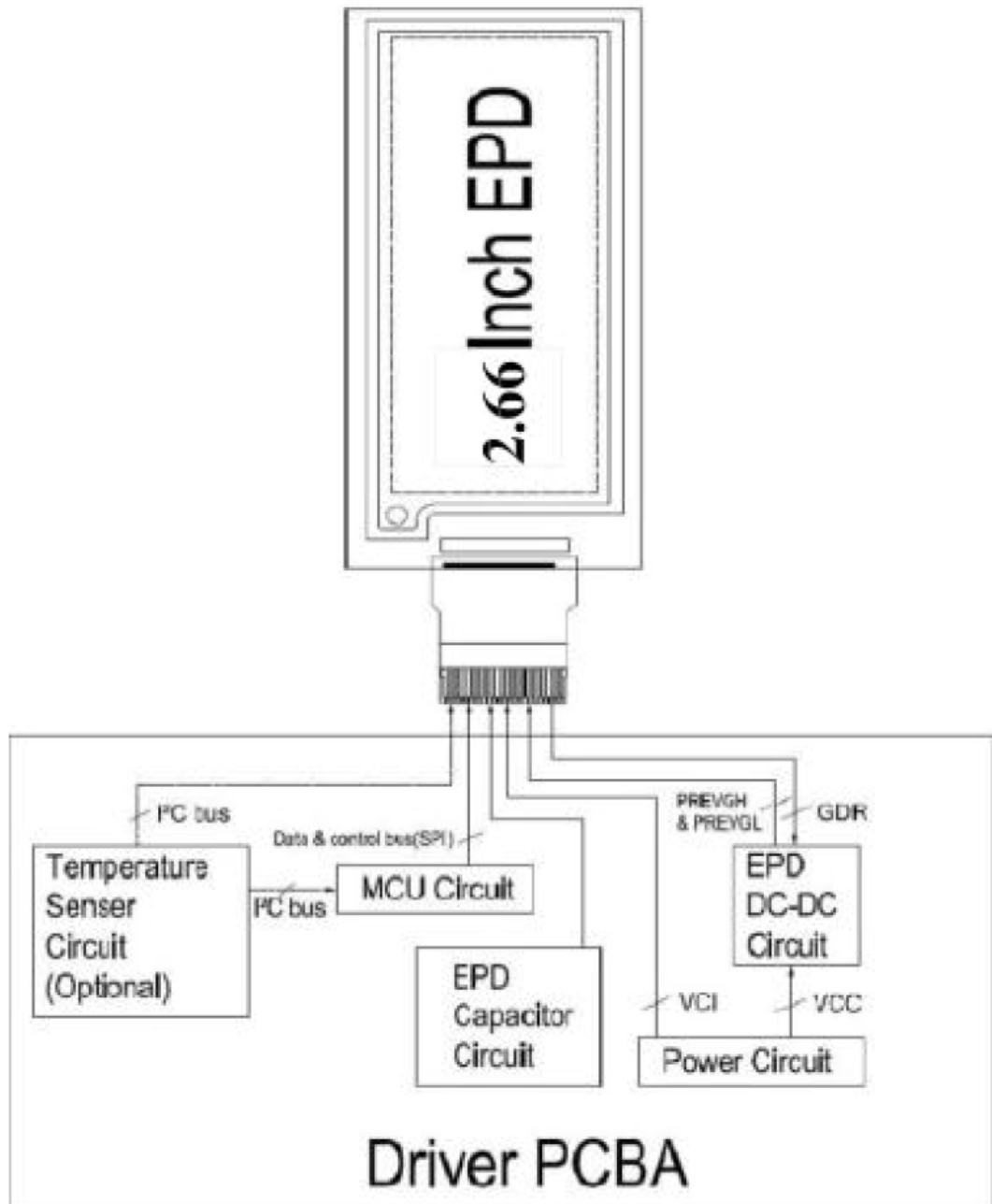

12. Typical Application Circuit

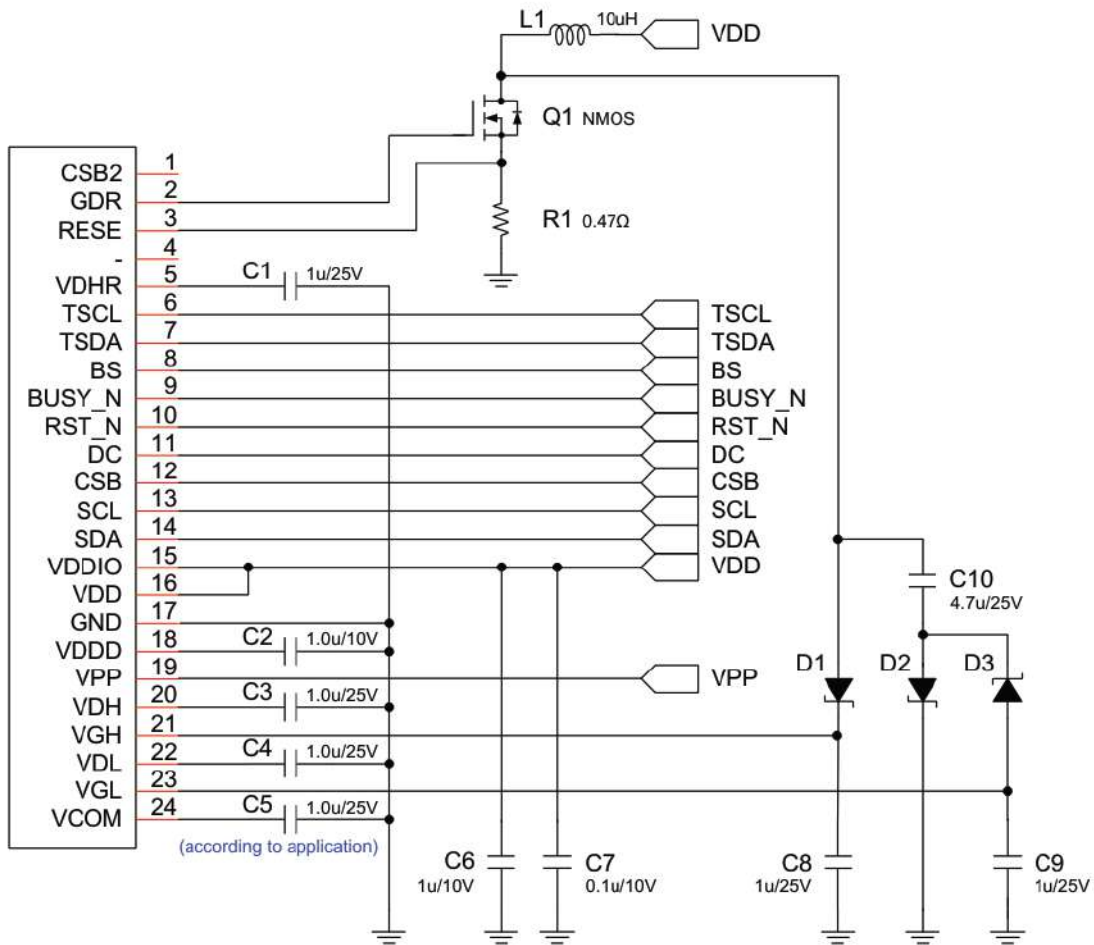

Note:

1. The capacitor value of VGH/VGL must be equal or more than the one of VSH/VSL/VDHR.

Recommended Device

1. Switch MOS NMOS: Vishay Si1308EDL ($V_{DS} > 25V$, $I_D > 500mA$, $V_{GS(th)} < 1.5V$, $C_{iss} < 200pF$, $R_{DS(on)} < 400m\Omega$)
2. Schottky Diode: OnSemi MBR0530 ($V_R > 25V$, $I_F > 500mA$, $I_R < 1mA @ V_R=15V$, $T_a=100^\circ C$)

Recommended Resistor

Item	Pins	Resistance
Powers	VDD, VDDA, VDDIO, GND, GNDA, VDM	< 10 Ω
Boosters	VGL, VGH, GDR, RESE	< 10 Ω
Regulators	VDH, VDL, VDHR, VCOM, VDDD, VDDDO	< 10 Ω
Logics	MS, BS, CSB, SCL, SDA, GDR, etc.	< 50 Ω
OTP	VPP	< 20 Ω

13. Part Number Definition

TBD

14. Inspection condition

14.1 Environment

Temperature: $25 \pm 3^{\circ}\text{C}$

Humidity: $55 \pm 10\% \text{RH}$

14.2 Illuminance

Brightness: 1200~1500LUX; distance: 20-30CM; Angle: Relate 30 surround.

14.3 Inspect method

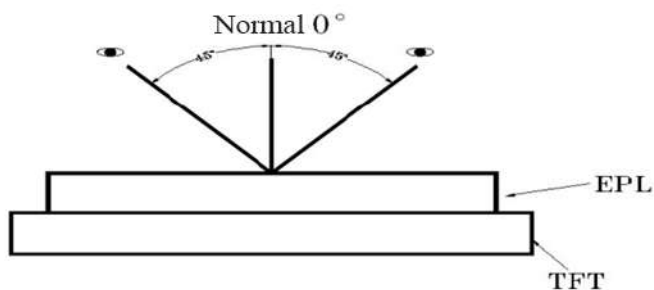

14.4 Display area

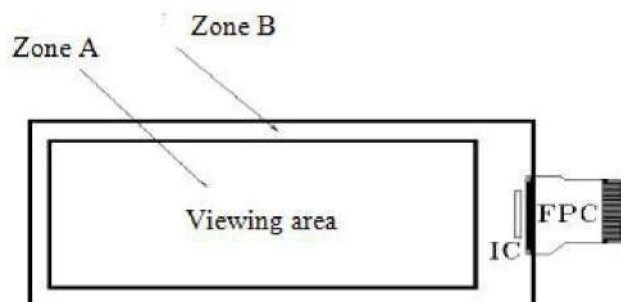

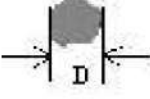
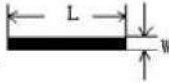

14.5 Inspection standard

14.5.1 Electric inspection standard

NO.	Item	Standard	Defect level	Method	Scope
1	Display	Display complete Display uniform	MA	Visual inspection	
2	Black/White spots	 $D \leq 0.25\text{mm}$, Allowed $0.25\text{mm} < D \leq 0.4\text{mm}$, $N \leq 3$, and Distance $\geq 5\text{mm}$ $0.4\text{mm} < D$ Not Allow	MI		
3	Black/White spots (No switch)	 $L \leq 0.6\text{mm}$, $W \leq 0.2\text{mm}$, $N \leq 1$ $L \leq 2.0\text{mm}$, $W > 0.2\text{mm}$, Not Allow $L > 0.6\text{mm}$, Not Allow		Visual/ Inspection card	Zone A
4	Ghost image	Allowed in switching process	MI	Visual inspection	
5	Flash spots/ Larger FPL size	Flash spots in switching, Allowed FPL size larger than viewing area, Allowed	MI	Visual/ Inspection card	Zone A Zone B
6	Display wrong/Missing	All appointed displays are showed correct	MA	Visual inspection	Zone A
7	Short circuit/ Circuit break/ Display abnormal	Not Allow			

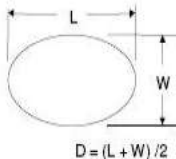
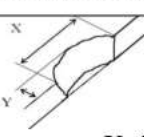
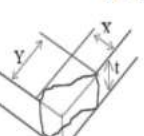
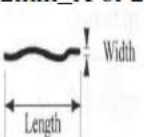
14.5.2 Appearance inspection standard

NO.	Item	Standard	Defect level	Method	Scope
1	B/W spots /Bubble/ Foreign bodies/ Dents	 $D = (L + W) / 2$ <p> $D \leq 0.25\text{mm}$, Allowed $0.25\text{mm} < D \leq 0.4\text{mm}$, $N \leq 3$ $D > 0.4\text{mm}$, Not Allow </p>	MI	Visual inspection	Zone A
2	Glass crack	Not Allow	MA	Visual / Microscope	Zone A Zone B
3	Dirty	Allowed if can be removed	MI		Zone A Zone B
4	Chips/Scratch/ Edge crown	 <p>$X \leq 3\text{mm}, Y \leq 0.5\text{mm}$</p>  <p>$2\text{mm} \leq X$ or $2\text{mm} \leq Y$ Allow</p>  <p> $W \leq 0.1\text{mm}, L \leq 5\text{mm}, n \leq 2$ Edge crown: $X \leq 0.3\text{mm}, Y \leq 3\text{mm}$ </p>	MI	Visual / Microscope	Zone A Zone B
5	Substrate color difference	Allowed			
6	FPC broken/ Goldfingers oxidation/ scratch	  <p>Not Allow</p>	MA	Visual / Microscope	Zone B

7	PCB damaged/ Poor welding/ Curl	PCB (Circuit area) damaged Not Allow PCB Poor welding Not Allow PCB Curl \leq 1%	MI	Visual / Ruler	Zone B
8	Edge Adhesives height/FPL/ Edge adhesives bubble	Edge Adhesives height \leq Display surface Edge adhesives seep in \leq 1/2 Margin width FPL tolerance \pm 0.3mm Edge adhesives bubble: bubble Width \leq 1/2 Margin width; Length \leq 0.5mm。 n \leq 3			
9	Protect film	Surface scratch but not effect protect function, Allow		Visual Inspection	

15. Packaging
TBD