



ORIENT DISPLAY

Your Total LCD Solution Provider

Specification for TFT

AFR240320A0-2.4INTM-I

Revision V1.0



A	Orient Display
FR	TFT Type
240320	Resolution 240x320
A0	Serial A0
2.4	2.4", Module Dimension 42.92x60.26x2.5 mm
I	IPS Display
N	Top: -20~+70°C; Tstr: -30~+80°C
T	Transmissive/Normally Black
M	Medium Brightness, 550cd/m2
I	MIPI + one data lane
/	No Touch Panel
/	Controller JD9852



Contents

1. MECHANICAL INFORMATION	4
2. BLOCK DIAGRAM.....	5
3. OUTLINE DIMENSION	6
4. INPUT TERMINAL PIN ASSIGNMENT	7
5. LCD OPTICAL CHARACTERISTICS	8
5.1 OPTICAL SPECIFICATION	8
5.2 MEASURING CONDITION	8
5.3 MEASURING EQUIPMENT.....	9
6. ELECTRICAL CHARACTERISTICS.....	11
6.1 ABSOLUTE MAXIMUM RATING (Ta=25 VSS=0V).....	11
6.2 DC ELECTRICAL CHARACTERISTICS.....	11
6.3 LED BACKLIGHT CHARACTERISTICS.....	12
7. AC CHARACTERISTIC.....	14
7.1 RESET INPUT TIMING	14
7.2 TIMINGS FOR DSI VIDEO MODE	15
8. LCD MODULE OUT-GOING QUALITY LEVEL.....	17
8.1 VISUAL & FUNCTION INSPECTION STANDARD.....	17
9. RELIABILITY TEST RESULT	22
10 CAUTIONS AND HANDLING PRECAUTIONS	23
10.1 HANDLING AND OPERATING THE MODULE	23
11. PACKING	25

1. Basic Specifications

This is a color active matrix TFT (Thin Film Transistor) LCD (liquid crystal display) that uses amorphous silicon TFT as a switching device. This module is composed of a Transmissive type TFT-LCD Panel, driver circuit, back-light unit. The resolution of a 2.4" TFT-LCD contains 240 X 320 pixels, and can display up to 65K/262K colors.

1.1 Features

General Information Items	Specification	Unit	Note
	Main Panel		
Display area(AA)	36.72(H)*48.96(V) (2.4inch)	mm	-
Driver element	TFT active matrix	-	-
Display colors	65K/262K	colors	-
Number of pixels	240(RGB)*320	dots	-
Pixel arrangement	RGB vertical stripe	-	-
Pixel pitch	0.153(H)*0.153(V)	mm	-
Viewing angle	FREE	o'clock	-
Controller IC	JD9852	-	-
LCM Interface	MIPI+one data lane	-	-
Display mode	Transmissive /Normally Black	-	-
Operating temperature	-20~+70	°C	-
Storage temperature	-30~+80	°C	-

1.2 Mechanical Information

Item		Min.	Typ.	Max.	Unit	Note
Module size	Horizontal(H)		42.92		mm	-
	Vertical(V)		60.26		mm	-
	Depth(D)		2.5		mm	-
Weight			11		g	-

2. Block Diagram

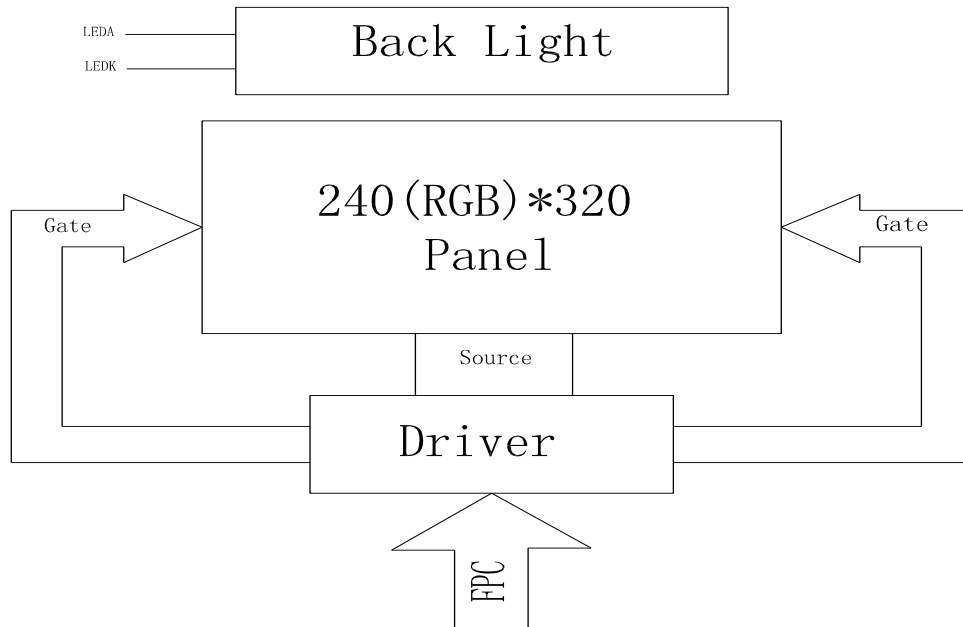

4. Input terminal Pin Assignment

Pin NO.	Symbol	Function	I/O
1	NC		
2	LEDK	Cathode pin of backlight.	P
3	NC		
4	LEDA	Anode pin of backlight.	P
5	NC		
6	VCI	Supply voltage (3.3V).	P
7	IOVCC	Power supply for I/O block(1.8-3.3V)	P
8	TE	Serve as a TE (Tearing Effect) output signal	O
9	RESET	Reset pin. Setting either pin low initializes the LSI. Must be reset after power is supplied.	I
10	GND	Ground.	P
11	NC		
12	NC		
13	GND	Ground.	P
14	MIPI_CL P	DSI Positive polarity of low voltage differential clock signal	I
15	MIPI_CL N	DSI Negative polarity of low voltage differential clock signal	
16	GND	Ground.	P
17	MIPI_D0 P	DSI Positive polarity of low voltage differential data signal	I
18	MIPI_D0 N	DSI Negative polarity of low voltage differential data signal	I
19	GND	Ground.	P
20	GND	Ground.	P

5. LCD Optical Characteristics

5.1 Optical specification

Item		Symbol	Condition	Min.	Typ.	Max.	Unit.	Note
Contrast Ratio		CR	$\Theta=0$	600	800			*(1)(2)
Response time	Rising	T_{R+T_F}	Normal viewing angle	--	16	21	msec	*(1)(3)
	Falling				19	24		
Color gamut		S(%)		-	70	--	%	*
Color Filter Chromaticity	White	W_X		0.2692	0.3092	0.3492	CA-310 Test	
		W_Y		0.2975	0.3375	0.3775		
	Red	R_X		0.5907	0.6307	0.6707		
		R_Y		0.3020	0.3420	0.3820		
	Green	G_X		0.2839	0.3239	0.3639		
		G_Y		0.5724	0.6124	0.6524		
	Blue	B_X		0.1087	0.1487	0.1887		
		B_Y		0.0096	0.0496	0.0896		
Viewing angle	Hor.	Θ_L	CR>10		80	--	*(1)(4)	
		Θ_R			80	--		
	Ver.	Θ_U			80	--		
		Θ_D			80	--		
Option View Direction		FREE						

*The data comes from the LCD specification.

5.2 Measuring Condition

- Measuring surrounding: dark room
- Ambient temperature: $25\pm 2^\circ\text{C}$
- 15min. warm-up time.

5.3 Measuring Equipment

- FPM520 of Westar Display technologies, INC., which utilized SR-3 for Chromaticity and BM-5A for other optical characteristics.

Note (1) Definition of Viewing Angle:

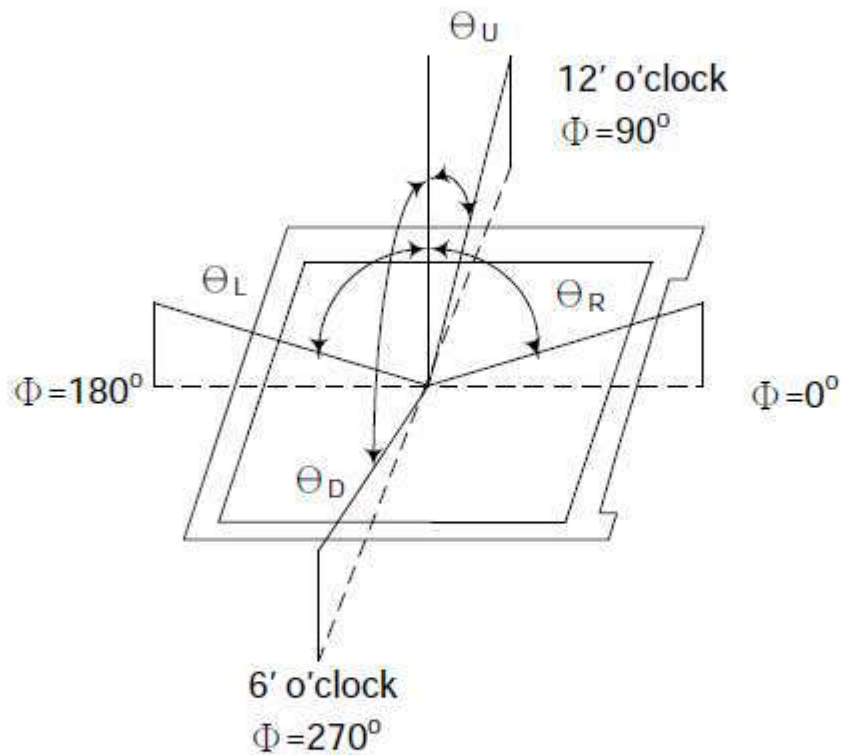

Note (2) Definition of Contrast Ratio (CR) :
measured at the center point of panel

$$CR = \frac{\text{Luminance with all pixels white}}{\text{Luminance with all pixels black}}$$

Note (3) Definition of Response Time : Sum of T_R and T_F

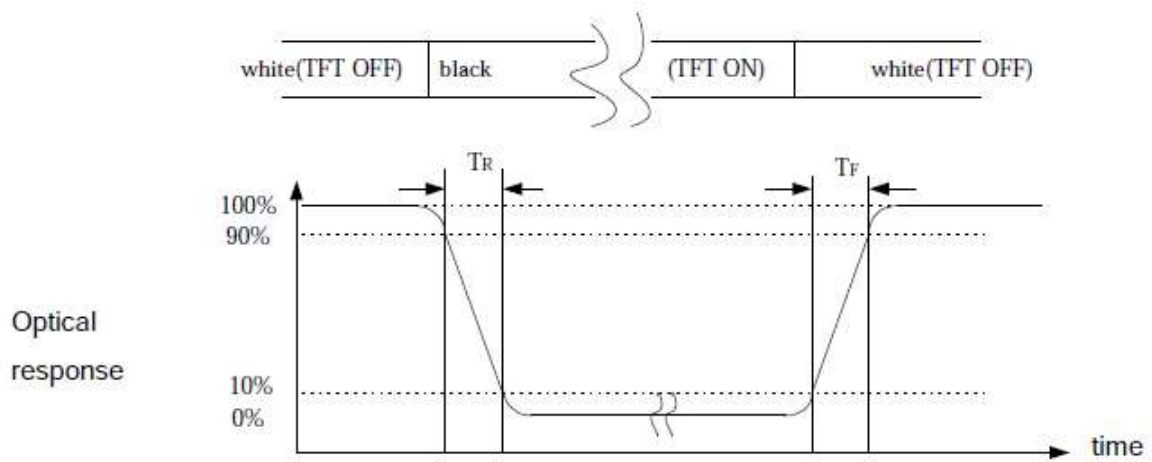

Note (4) Definition of optical measurement setup

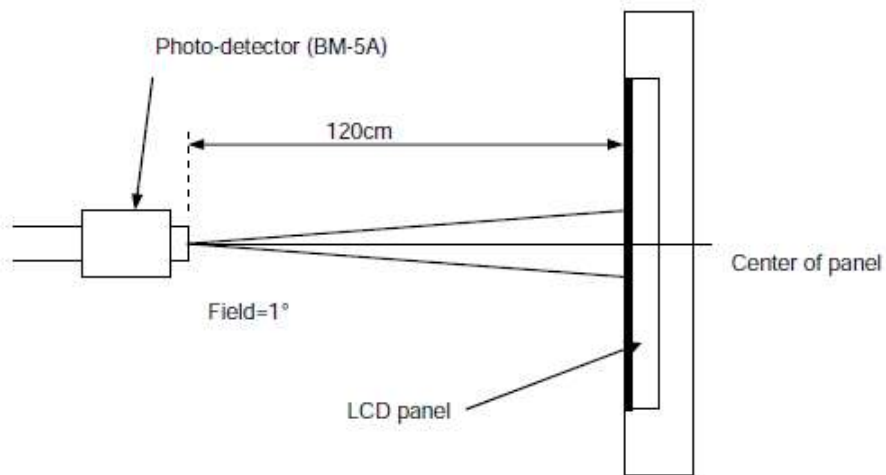

6. Electrical Characteristics

6.1 Absolute Maximum Rating (Ta=25 VSS=0V)

Characteristics	Symbol	Min.	Max.	Unit
Digital Supply Voltage	VCI	-0.3	3.3	V
Digital interface supply Voltage	IOVCC	-0.3	3.3	V
Operating temperature	T _{OP}	-20	+70	°C
Storage temperature	T _{ST}	-30	+80	°C

NOTE: If the absolute maximum rating of even is one of the above parameters is exceeded even momentarily,

the quality of the product may be degraded. Absolute maximum ratings, therefore, specify the values

exceeding which the product may be physically damaged. Be sure to use the product within the range

of the absolute maximum ratings.

6.2 DC Electrical Characteristics

Characteristics	Symbol	Min.	Typ.	Max.	Unit	Note
Digital Supply Voltage	VCI	2.6	3.3	3.6	V	
Digital interface supply Voltage	IOVCC	1.65	1.8	3.3	V	
Normal mode Current consumption	IDD	--	9	--	mA	
Level input voltage	V _{IH}	0.7I _{OVCC}		I _{OVCC}	V	
	V _{IL}	GND		0.3I _{OVCC}	V	
Level output voltage	V _{OH}	0.8I _{OVCC}		I _{OVCC}	V	
	V _{OL}	GND		0.2I _{OVCC}	V	

6.3 LED Backlight Characteristics

The back-light system is edge-lighting type with 4 chips White LED

Item	Symbol	Min.	Typ.	Max.	Unit	Note
Forward Current	I_F	15	20	--	mA	
Forward Voltage	V_F	--	12.8	--	V	
LCM Luminance	L_v	500	550	--	cd/m ²	Note3
LED life time	Hr	50000	--	--	Hour	Note1,2
Uniformity	AVg	80	--	--	%	Note3

Note (1) LED life time (Hr) can be defined as the time in which it continues to operate under the condition: $T_a=25\pm3$ °C, typical IL value indicated in the above table until the brightness becomes less than 50%.

Note (2) The “LED life time” is defined as the module brightness decrease to 50% original brightness at $T_a=25^\circ\text{C}$ and $I_L=20\text{mA}$. The LED lifetime could be decreased if operating I_L is larger than 20mA. The constant current driving method is suggested.

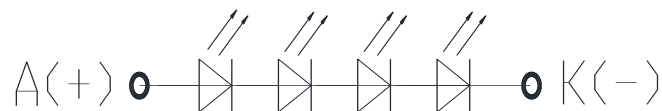

BLU CIRCUIT DIAGRAM

NOTE 3: Luminance Uniformity of these 9 points is defined as below:

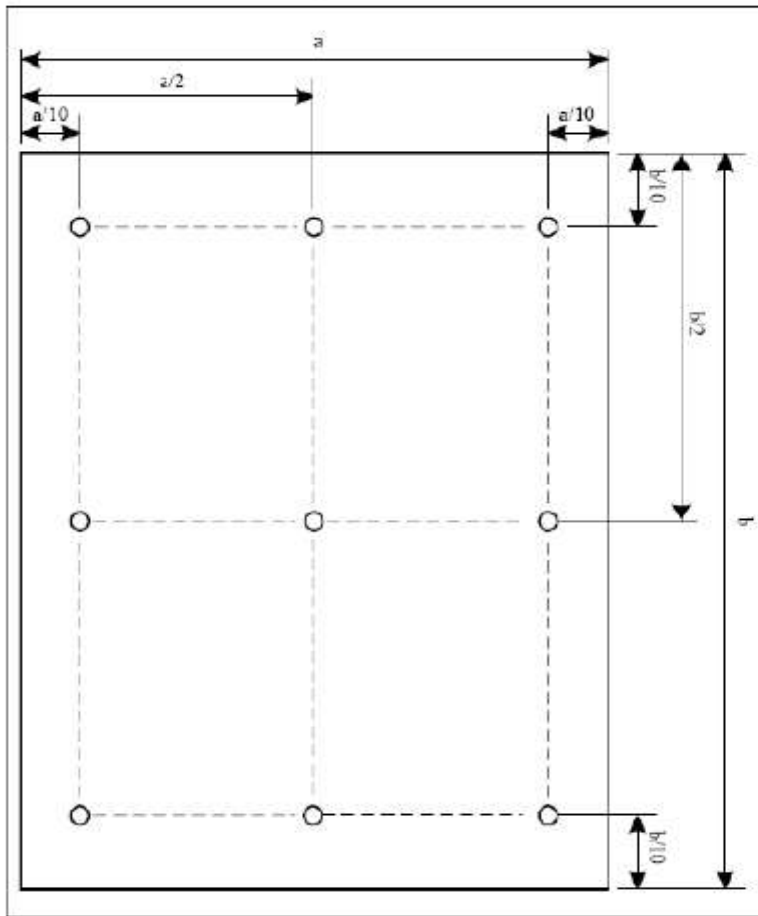

$$\text{Uniformity} = \frac{\text{minimum luminance in 9 points (1-9)}}{\text{maximum luminance in 9 points (1-9)}}$$

$$\text{Luminance} = \frac{\text{Total Luminance of 9 points}}{9}$$

7. AC Characteristic

7.1 Reset Input Timing

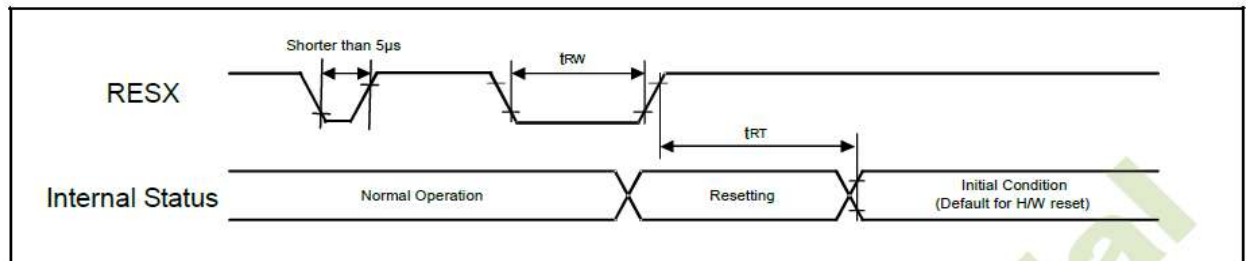

* Reset input timings

Symbol	Parameter	Related pins	Min.	Max.	Unit
t_{RW}	Reset pulse width ⁽²⁾	RESX	10	-	μs
t_{RT}	Reset complete time ⁽³⁾	-	-	5 (Note 5)	ms
		-	-	120 (Note 6, 7)	ms

Note: (1) The reset complete time also required time for loading ID bytes from OTP to registers. This loading is done every time when there is HW reset cancel time (t_{RT}) within 5 ms after a rising edge of RESX.

(2) Spike due to an electrostatic discharge on RESX line does not cause irregular system reset according to the table below.

RESX Pulse	Action
Shorter than 5 μs	Reset Rejected
Longer than 10 μs	Reset
Between 5 μs and 10 μs	Reset Start

(3) During the resetting period, the display will be blanked (The display is entering blanking sequence, which maximum time is 120 ms, when Reset Starts in Sleep Out –mode. The display remains the blank state in Sleep In –mode) and then returns to Default condition for H/W reset.

(4) Spike Rejection also applies during a valid reset pulse as shown below:

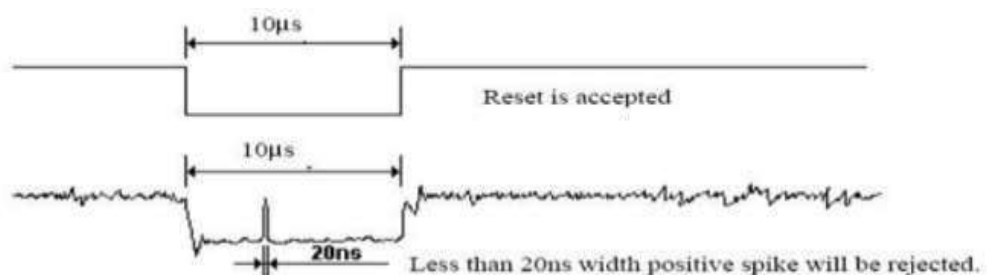

(5) When Reset is applied during Sleep In Mode.

(6) When Reset is applied during Sleep Out Mode.

(7) It is necessary to wait 5msec after releasing RESX before sending commands. Also Sleep Out command cannot be sent for 120msec.

7.2 Timings for DSI Video mode

Vertical Timings

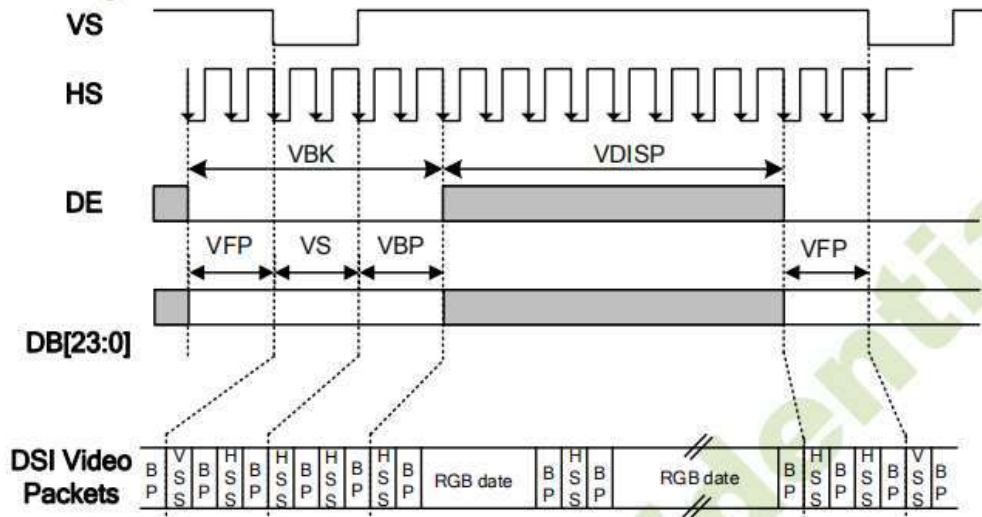

Vertical Timings for DSI Video mode I/F

Resolution=240x320 (TA=25°C, IOVCC=1.8V, VCI=2.8V)

Item	Symbol	Condition	Min.	Typ.	Max.	Unit
Vertical low pulse width	VS	-	2	-	Note(1)	Line
Vertical front porch	VFP	-	2	-	-	Line
Vertical back porch	VBP	-	2	-	Note(1)	Line
Vertical blanking period	VBK	VS+VBP+VFP	6	-	-	Line
Vertical active area	-	VDISP	-	320	-	Line
Vertical Refresh rate	VRR	-	-	60	-	Hz

Vertical Timings for DSI Video mode I/F

Horizontal Timings

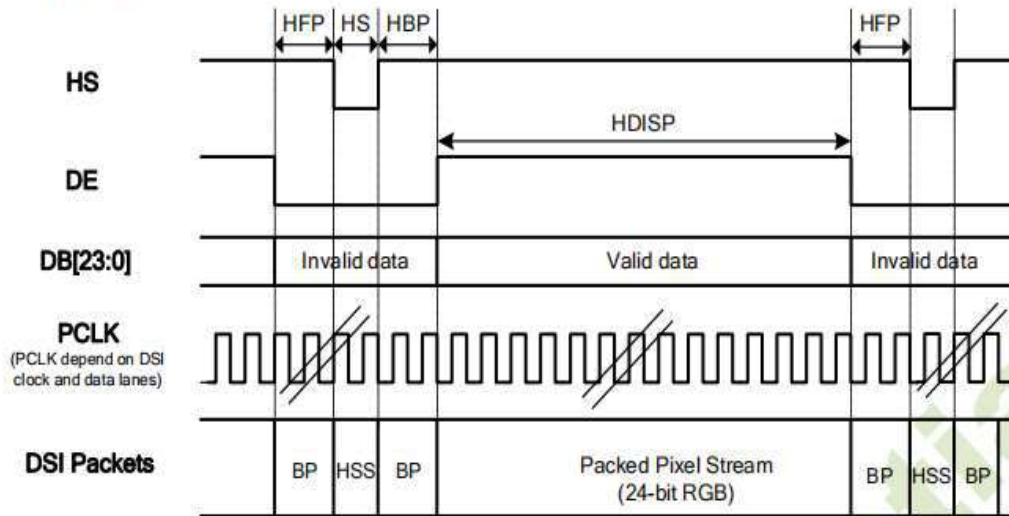

Horizontal Timing for DSI Video mode I/F

Resolution=240x320 (TA=25°C, IOVCC=1.8V, VCI=2.8V)

Item	Symbol	Condition	Min.	Typ.	Max.	Unit
HS low pulse width	HS	-	6	-	78	DCK
Horizontal back porch	HBP	-	5	-	78	DCK
Horizontal front porch	HFP	-	5	-	78	DCK
Horizontal blanking period	HBLK	HS+HBP+HFP	16	-	88	DCK
Horizontal active area	HDISP	-	-	240	-	DCK

Note: (1) HS+HBP>0.5uS.

(2) HFP>0.5uS.

Horizontal Timings for DSI Video mode I/F

8. LCD Module Out-Going Quality Level

8.1 VISUAL & FUNCTION INSPECTION STANDARD

8.1.1 Inspection conditions

Inspection performed under the following conditions is recommended.

Temperature : $25\pm 5^{\circ}\text{C}$

Humidity : $65\%\pm 10\%\text{RH}$

Viewing Angle : Normal viewing Angle.

Illumination: Single fluorescent lamp (300 to 700Lux)

Viewing distance:30-50cm

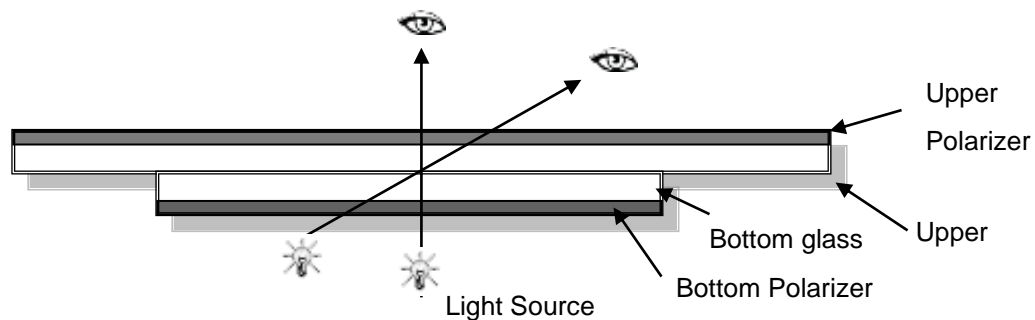

8.1.2 Definition

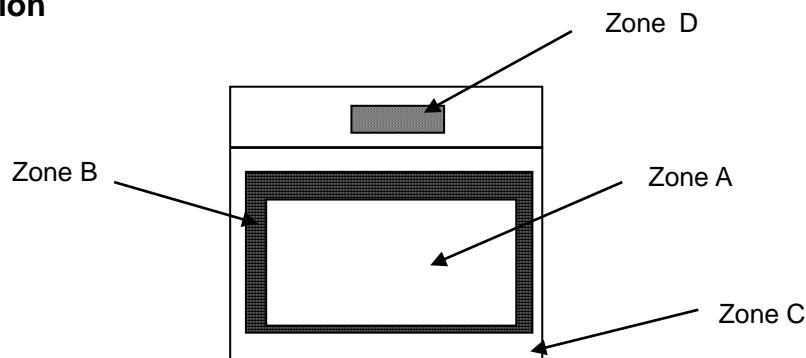

Zone A : Effective Viewing Area(Character or Digit can be seen)

Zone B : Viewing Area except Zone A

Zone C : Outside (Zone A+Zone B) which can not be seen after assembly by customer .)

Zone D : IC Bonding Area

Note:

As a general rule ,visual defects in Zone C can be ignored when it doesn't effect

product function or appearance after assembly by customer

8.1.3 Sampling Plan

According to GB/T 2828-2003 ; , normal inspection, Class II

AQL:

Major defect	Minor defect
0.65	1.5

LCD: Liquid Crystal Display , TP: Touch Panel , LCM: Liquid Crystal Module

No	Items to be inspected	Criteria	Classification of defects
1	Functional defects	1) No display, Open or miss line 2) Display abnormally, Short 3) Backlight no lighting, abnormal lighting. 4) TP no function	Major
2	Missing	Missing component	
3	Outline dimension	Overall outline dimension beyond the drawing is not allowed	
4	Color tone	Color unevenness, refer to limited sample	Minor
5	Spot Line defect	Light dot , Dim spot , Polarizer Bubble ; Polarizer accidented spot.	
6	Soldering appearance	Good soldering , Peeling off is not allowed.	
7	LCD/Polarizer/TP	Black/White spot/line, scratch, crack, etc.	

8.1.4 Criteria (Visual)

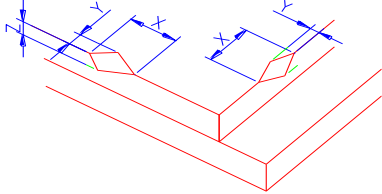
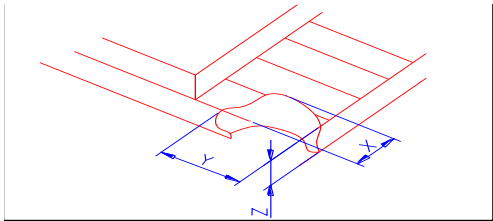
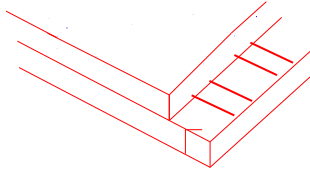
Number	Items	Criteria(mm)						
1.0 LCD Crack/Broken NOTE: X: Length Y: Width Z: Height L: Length of ITO, T: Height of LCD	(1) The edge of LCD broken	 <table border="1" data-bbox="748 647 1401 795"> <thead> <tr> <th>X</th> <th>Y</th> <th>Z</th> </tr> </thead> <tbody> <tr> <td>≤3.0mm</td> <td><Inner border line of the seal</td> <td>≤T</td> </tr> </tbody> </table>	X	Y	Z	≤3.0mm	<Inner border line of the seal	≤T
	X	Y	Z					
	≤3.0mm	<Inner border line of the seal	≤T					
(2) LCD corner broken	 <table border="1" data-bbox="804 1104 1345 1202"> <thead> <tr> <th>X</th> <th>Y</th> <th>Z</th> </tr> </thead> <tbody> <tr> <td>≤3.0mm</td> <td>≤L</td> <td>≤T</td> </tr> </tbody> </table>	X	Y	Z	≤3.0mm	≤L	≤T	
X	Y	Z						
≤3.0mm	≤L	≤T						
(3) LCD crack	 <p style="text-align: center;">Crack Not allowed</p>							

2.0

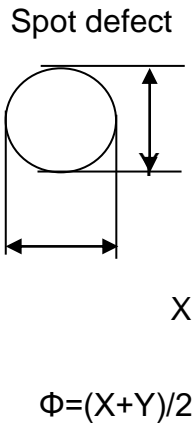

① light dot (LCD/TP/Polarizer black/white spot , light dot, pinhole, dent, stain)

Zone Size (mm)	Acceptable Qty		
	A	B	C
$\Phi \leq 0.10$	Ignore		Ignore
$0.10 < \Phi \leq 0.20$	3(distance $\geq 10\text{mm}$)		
$0.20 < \Phi \leq 0.25$	2		
$\Phi > 0.3$	0		

② Dim spot (LCD/TP/Polarizer dim dot, light leakage, dark spot)

Zone Size (mm)	Acceptable Qty		
	A	B	C
$\Phi \leq 0.1$	Ignore		Ignore
$0.10 < \Phi \leq 0.20$	3(distance $\geq 10\text{mm}$)		
$0.20 < \Phi \leq 0.25$	2		
$\Phi > 0.3$	0		

③ Polarizer accidented spot

Zone Size (mm)	Acceptable Qty		
	A	B	C
$\Phi \leq 0.2$	Ignore		Ignore
$0.3 < \Phi \leq 0.5$	2(distance $\geq 10\text{mm}$)		
$\Phi > 0.5$	0		

④ Pixel bad points (light dot, Dim dot, color dot)

Zone Size (mm)	Acceptable Qty		
	A	B	C
$\Phi \leq 0.1$	Ignore		Ignore
$0.15 < \Phi \leq 0.2$	2(distance \geq		
$\Phi > 0.2$	0		

⑤ Polarizer Bubble

Zone Size (mm)	Acceptable Qty		
	A	B	C
$\Phi \leq 0.2$	Ignore		Ignore
$0.3 < \Phi \leq 0.4$	3(distance $\geq 10\text{ m}$)		
$0.4 < \Phi \leq 0.5$	2		
$\Phi > 0.5$	0		

3.0	Line defect (LCD/TP /Polarizer backlight black/white line, scratch, stain)	Width(mm)	Length(mm)	Acceptable Qty		
				A	B	C
		$\Phi \leq 0.03$	Ignore	Ignore		
		$0.03 < W \leq 0.04$	$L \leq 3.0$	N \leq 2		
		$0.04 < W \leq 0.05$	$L \leq 2.0$	N \leq 1		
	$0.05 < W$	Define as spot defect				
4.0	Electronic Components SMT	Not allow missing parts, solderless connection, cold solder joint, mismatch, The positive and negative polarity opposite				
5.0	Display color & Brightness	<p>1. Color: Measuring the color coordinates, The measurement standard according to the datasheet or samples.</p> <p>2. Brightness: Measuring the brightness of White screen, The measurement standard according to the datasheet or Samples.</p>				
6.0	LCD Mura	By 5% ND filter invisible.				

Criteria (functional items)

Number	Items	Criteria (mm)
1	No display	Not allowed
2	Missing segment	Not allowed
3	Short	Not allowed
4	Backlight no lighting	Not allowed
5	TP no function	Not allowed

9. Reliability Test Result

Item	Condition	Inspection after test
High Temperature Operating	70°C, 96H	Inspection after 2~4hours storage at room temperature, the sample shall be free from defects: 1.Air bubble in the LCD; 2.Non-display; 3.Missing segments/line; 4.Glass crack; 5.Current IDD is twice higher than initial value.
Low Temperature Operating	-20°C, 96HR	
High Temperature Storage	80°C, 96HR	
Low Temperature Storage	-30°C, 96HR	
High Temperature & High Humidity Operating	+60°C, 90% RH ,96 hours.	
Thermal Shock (Non- operation)	-30°C, 30 min ↔ 80°C, 30 min, Change time:5min 20CYC.	
ESD test	C=150pF, R=330, 5points/panel Air:±8KV, 5times; Contact:±6KV, 5 times; (Environment: 15°C~35°C, 30%~60%).	
Vibration (Non- operation)	Frequency range:10~55Hz, Stroke:1.5mm Sweep:10Hz~55Hz~10Hz 2 hours for each direction of X.Y.Z. (6 hours for total) (Package condition).	
Box Drop Test	1 Corner 3 Edges 6 faces, 80cm (MEDIUM BOX)	

Remark:

1.The test samples should be applied to only one test item.

2. Sample size for each test item is 5~10pcs.
3. For Damp Proof Test, Pure water (Resistance > 10M Ω) should be used.
4. In case of malfunction defect caused by ESD damage, if it would be recovered to normal state after resetting, it would be judged as a good part.
5. Failure Judgment Criterion: Basic Specification, Electrical Characteristic, Mechanical Characteristic, Optical Characteristic.

10 Cautions and Handling Precautions

10.1 Handling and Operating the Module

- (1) When the module is assembled, it should be attached to the system firmly.

Do not warp or twist the module during assembly work.

- (2) Protect the module from physical shock or any force. In addition to damage, this may cause improper operation or damage to the module and back-light unit.

- (3) Note that polarizer is very fragile and could be easily damaged. Do not press or scratch the surface.

- (4) Do not allow drops of water or chemicals to remain on the display surface.

If you have the droplets for a long time, staining and discoloration may occur.

- (5) If the surface of the polarizer is dirty, clean it using some absorbent cotton or soft cloth.

- (6) The desirable cleaners are water, IPA (Isopropyl Alcohol) or Hexane.

Do not use ketene type materials (ex. Acetone), Ethyl alcohol, Toluene, Ethyl acid or Methyl chloride.

It might permanent damage to the polarizer due to chemical reaction.

- (7) If the liquid crystal material leaks from the panel, it should be kept away from the eyes or mouth. In case of contact with hands, legs, or clothes, it must be washed away thoroughly with soap.

- (8) Protect the module from static; it may cause damage to the CMOS ICs.

- (9) Use finger-stalls with soft gloves in order to keep display clean during the incoming inspection and assembly process.

- (10) Do not disassemble the module.

- (11) Protection film for polarizer on the module shall be slowly peeled off just before use so that the electrostatic charge can be minimized.

- (12) Pins of I/F connector shall not be touched directly with bare hands.

- (13) Do not connect, disconnect the module in the "Power ON" condition.

- (14) Power supply should always be turned on/off by the item 6.1 Power On Sequence & 6.2 Power Off Sequence

10.2 Storage and Transportation.

(1) Do not leave the panel in high temperature, and high humidity for a long time.

It is highly recommended to store the module with temperature from 0 to 35 °C and relative humidity of less than 70%

(2) Do not store the TFT-LCD module in direct sunlight.

(3) The module shall be stored in a dark place. When storing the modules for a long time, be sure to adopt effective measures for protecting the modules from strong ultraviolet radiation, sunlight, or fluorescent light.

(4) It is recommended that the modules should be stored under a condition where no condensation is allowed. Formation of dewdrops may cause an abnormal operation or a failure of the module.

In particular, the greatest possible care should be taken to prevent any module from being operated where condensation has occurred inside.

(5) This panel has its circuitry FPC on the bottom side and should be handled carefully in order not to be stressed.

11. Packing

