

960/900/864/816-Output Channels TFT LCD Gate Driver

Specification Preliminary

Version: V0.05
Document No.: ILI5960_SPEC_V0.05.pdf

ILI TECHNOLOGY CORP.

8F, No.38, Taiyuan St., Jhubei City, Hsinchu County 302,
Taiwan, R.O.C
Tel.886-3-5600099; Fax.886-3-5600055
<http://www.ilitek.com>

Table of Contents

Section	Page
1. Introduction.....	2
2. Features	2
4. Pin Descriptions	4
5. Operation Description	5
5.1 Device operation principle.....	5
5.2 Device operation	6
5.3 Mode (output channel) selection.....	8
5.4 Relationship between RL, STVR and STVL	9
5.5 Device power supply	10
5.6 Power ON/OFF Sequence	11
5.7 Start Pulse Input Limitation	13
6. DC Characteristic	14
6.1 Absolute Maximum Rating	14
6.2 Recommended operating conditions	14
6.3 Electrical Characteristics.....	15
7. AC Characteristic	16
8. Timing Chart.....	17
9. Pin Assignment (IC Face View).....	18
10. Pad Location	19
11. Bump Mask Information	26
12. Revision History	28

ILITEK CONFIDENTIAL

1. Introduction

ILI5960 is a 960/900/864/816-channel outputs gate driver used for driving the gate of TFT LCD panel. After a start pulse is triggered, output pins will output high-driving voltage pulses sequentially for the gate signals of the LCD Panel. This chip also provides shift up/down selection and cascade functions for dot expansion.

2. Features

- 2-level output gate driver for TFT LCD panel
- High voltage CMOS process technology COG package
- 960/900/864/816 channels output and 2 channel outputs which are fixed to VEE
- Bi-directional data shift capability
- Double gate sequence control function
- Maximum +40V output driving voltage
- 200KHz maximum operation frequency
- Cascade function for dot-expansion
- 2.7 ~ 3.6V logical interface

LITEK CONFIDENTIAL

3. Block Diagram

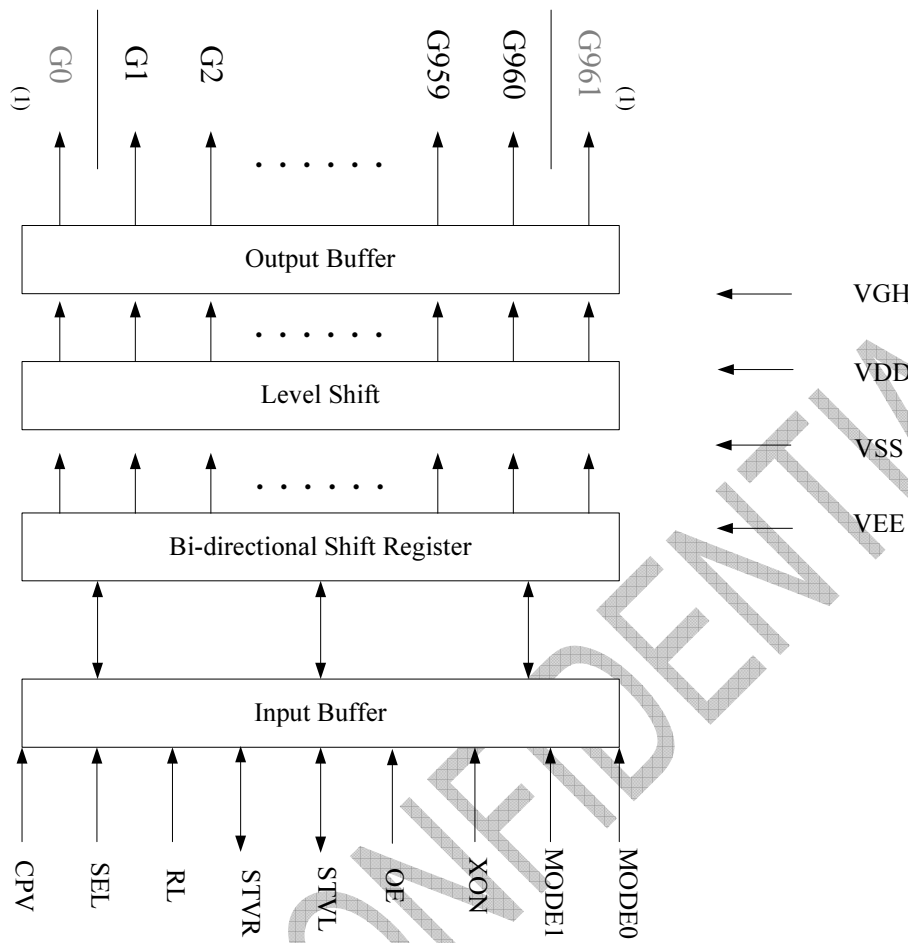

* Note: (1) G0 and G961 are LCD panel auxiliary pins. These pins always keep at VEE.

4. Pin Descriptions

Pin Name	I/O	Function	Descriptions																				
CPV	I	Shift clock input	This is the clock input for chip internal shift register. Data is shifted at each rising edge of this clock.																				
SEL <i>(Pull-high)</i>	I	Operating or testing	SEL=H:Normal Operating. Normal pull up. SEL=L:for testing.																				
RL	I	Shift direction control pin	This pin controls the output shifting direction as listed below. RL =H:STVR→G1→G2→...→G959→G960→STVL RL =L:STVL→G960→G959→...→G2→G1→STVR																				
STVR STVL	I/O	Start pulse input/output pin	These two pins are the device start pulse input or output pin. The function of these two pins depends on the status of RL pin. <table border="1" style="margin-left: auto; margin-right: auto;"> <thead> <tr> <th></th> <th>STVR</th> <th>STVL</th> </tr> </thead> <tbody> <tr> <td>RL=H</td> <td>input</td> <td>output</td> </tr> <tr> <td>RL=L</td> <td>output</td> <td>input</td> </tr> </tbody> </table>		STVR	STVL	RL=H	input	output	RL=L	output	input											
	STVR	STVL																					
RL=H	input	output																					
RL=L	output	input																					
OE	I	Output enable control	The OE signal controls the output enable. OE=H: All driver outputs are fixed to VEE regardless of CPV. However, the content of shift register is not cleared. OE=L: Normal operation.																				
XON <i>(Pull-high)</i>	I	Output all-on control	When XON input pin is L, all the output pins are forced to VGH level. Note that this pin has higher priority than OE. The chip internal shift register is not cleared when XON input is active. <i>Remark: Also it has an internal pull high resistor, keep it to VDD is preferred when unused.</i>																				
MODE <i>(pull-high)</i>	I	Output Channel number selection	They is the output channel number selection pin: <table border="1" style="margin-left: auto; margin-right: auto;"> <thead> <tr> <th>MODE1</th> <th>MODE0</th> <th>Output channel</th> <th>Disable Channel</th> </tr> </thead> <tbody> <tr> <td>H</td> <td>H</td> <td>960</td> <td>--Default</td> </tr> <tr> <td>H</td> <td>L</td> <td>900</td> <td>G453~G512</td> </tr> <tr> <td>L</td> <td>H</td> <td>864</td> <td>G433~G528</td> </tr> <tr> <td>L</td> <td>L</td> <td>816</td> <td>G409~G552</td> </tr> </tbody> </table> <i>Remark: Internal normal pull high.</i>	MODE1	MODE0	Output channel	Disable Channel	H	H	960	--Default	H	L	900	G453~G512	L	H	864	G433~G528	L	L	816	G409~G552
MODE1	MODE0	Output channel	Disable Channel																				
H	H	960	--Default																				
H	L	900	G453~G512																				
L	H	864	G433~G528																				
L	L	816	G409~G552																				
G1 ~ G960	O	Driver output pins for driving gate electrode of LCD	The output voltage is either VGH or VEE for driving the gate electrode of TFT LCD panel depending on the data stored in shift register and the state of OE																				
G0 G961	O	Auxiliary pins	LCD panel auxiliary pins, these pins always output VEE level.																				
VGH	P	Power supply	Power supply for Gate drive output High																				
VDD	P	Power supply	Digital power																				

Pin Name	I/O	Function	Descriptions
VSS	P	Power supply	Digital ground
VEE	P	Power supply	Power supply for Gate drive output low.
PASS	S	Internal link	Linked together internal.
SHIELDING1 ~ SHIELDING187	SD	Auxiliary pins	This pin is connected to VEE internally. Not connected.

Note1: I: Input; O: Output; I/O: Input/Output; P: Power; S: Shorted line; SD: Shielding pad

Note2: The unused input pins are recommended that this pin be connected to either VDD or VSS.

5. Operation Description

5.1 Device operation principle

In the condition of MODE=Default & RL=H, the STVR start pulse input is sensed at the rising edge of CPV and stored in the first stage of shift register, which causes the first scan signal is outputted from the OUT1 output pin. While stored data is transferred to the next stage shift register at the rising edge of next CPV, new data of STVR is sensed and stored simultaneously.

The output pin (G1 to G960) supplies VGH voltage or VEE voltage to the LCD panel depending on the data stored in the shift register. For normal operation, a VGH voltage is outputted one by one from G1 to G960 in sync with CPV pulse.

After 960 CLK rising edge are past, the STVL goes up to high level at the 960th falling edge of CPV and goes down to low level at the 961st falling edge of CPV. This STVL output signal becomes the STVR start pulse input of next cascaded gate driver device.

During any H state of OE, the corresponding output channels are forced to VEE level regardless of CPV. The channel output returns to normal status as soon as OE go back to L. The mechanism is as shown below!

5.2 Device operation

MODE=Default, RL=H

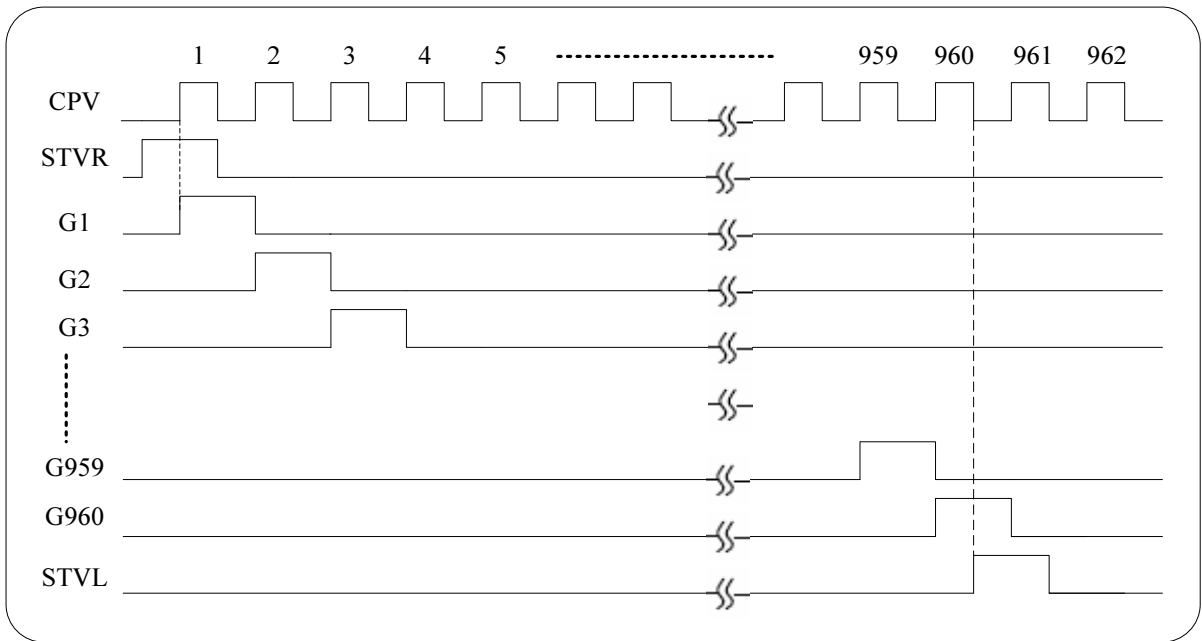

MODE=Default, RL=L

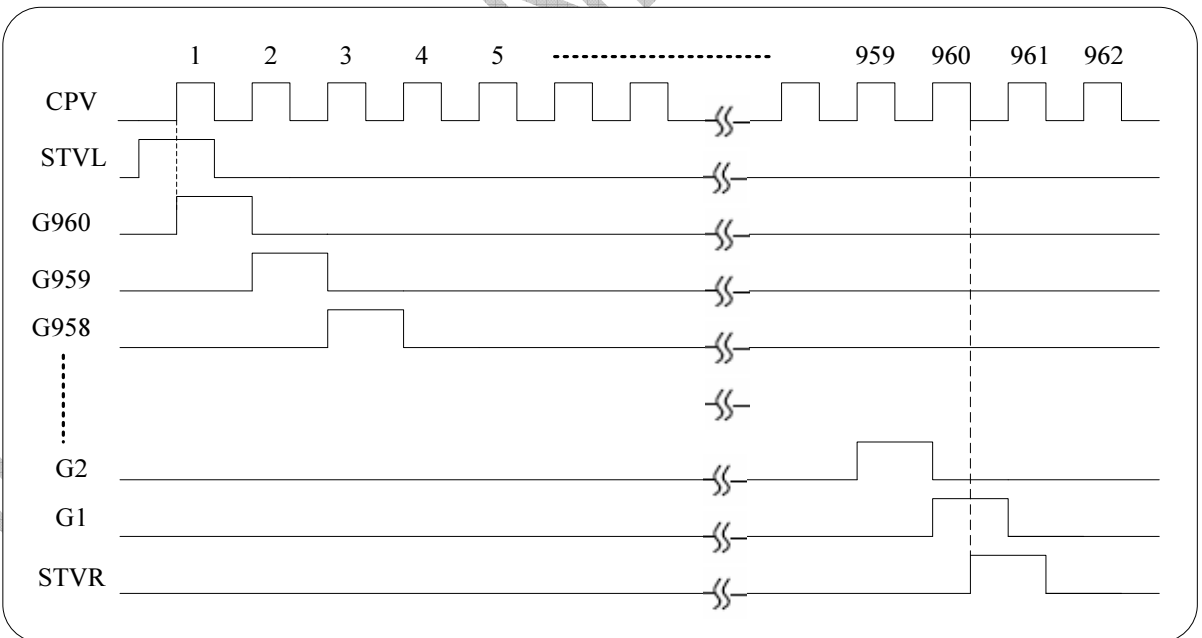

MODE=Default, RL=H with OE and XON

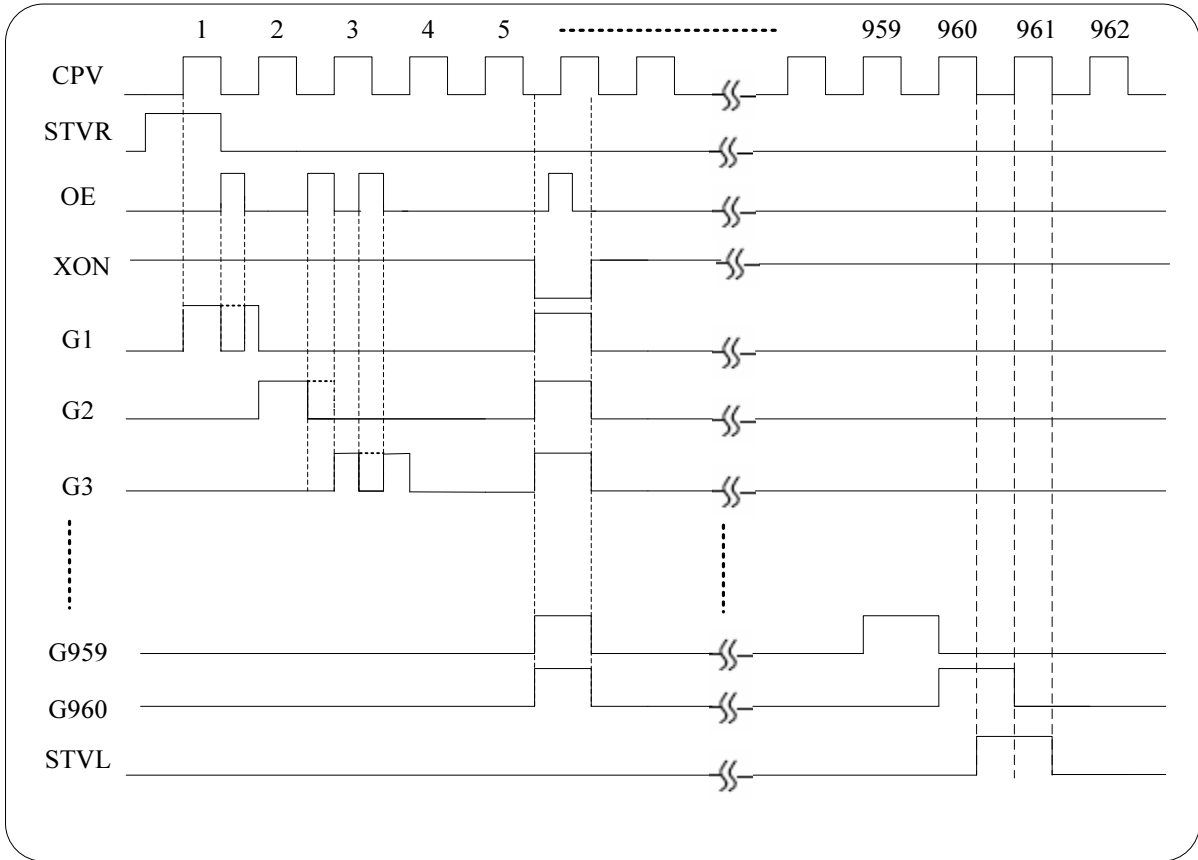

LITEK.COM

5.3 Mode (output channel) selection

Output channel number can choose between by MODE1 and MODE0 pin. The following table explains the relationship!

Output Channel	MODE1=H MODE0=H	MODE1=H MODE0=L	MODE1=L MODE0=H	MODE1=L MODE0=L
	960CH	900CH	864CH	816CH
G1	1st	1st	1st	1st
G2	2nd	2nd	2nd	2nd
:	:	:	:	:
G408	408th	408th	408th	408th
G409	409th	409th	409th	Fix to VEE
:	:	:	:	:
G430	430th	430th	430th	Fix to VEE
G431	431th	431th	431th	Fix to VEE
G432	432th	432th	432th	Fix to VEE
G433	433th	433th	Fix to VEE	Fix to VEE
G434	434th	434th	Fix to VEE	Fix to VEE
:	:	:	:	:
G451	451th	451th	Fix to VEE	Fix to VEE
G452	452th	452th	Fix to VEE	Fix to VEE
G453	453th	Fix to VEE	Fix to VEE	Fix to VEE
G454	454th	Fix to VEE	Fix to VEE	Fix to VEE
:	:	:	:	:
G511	511th	Fix to VEE	Fix to VEE	Fix to VEE
G512	512th	Fix to VEE	Fix to VEE	Fix to VEE
G513	513th	513th	Fix to VEE	Fix to VEE
G514	514th	514th	Fix to VEE	Fix to VEE
G515	515th	515th	Fix to VEE	Fix to VEE
:	:	:	Fix to VEE	Fix to VEE
:	:	:	:	:
G528	528th	528th	Fix to VEE	Fix to VEE
G529	529th	529th	529th	Fix to VEE
:	:	:	:	:
G552	552th	552th	552th	Fix to VEE
G553	553th	553th	553th	553th
:	:	:	:	:
G959	959th	959th	959th	959th
G960	960th	960th	960th	960th

5.4 Relationship between RL, STVR and STVL

MODE1=H MODE0=H →960CH

RL	Start pulse		Data transfer direction
	Input	Output	
H	STVR	STVL	G001 → G002 → ...G452 → G513 → ...G959 → G960
L	STVL	STVR	G960 → G959... → G513 → G452 → ... → G002 → G001

MODE1=H MODE0=L →900CH

RL	Start pulse		Data transfer direction
	Input	Output	
H	STVR	STVL	G001 → G002 → ...G452 → G513 → ...G959 → G960
L	STVL	STVR	G960 → G959... → G513 → G452 → ... → G002 → G001

MODE1=L MODE0=H →864CH

RL	Start pulse		Data transfer direction
	Input	Output	
H	STVR	STVL	G001 → G002 → ...G432 → G529 → ...G959 → G960
L	STVL	STVR	G960 → G959... → G529 → G432 → ... → G002 → G001

MODE1=L MODE0=L →816CH

RL	Start pulse		Data transfer direction
	Input	Output	
H	STVR	STVL	G001 → G002 → ...G408 → G553 → ...G959 → G960
L	STVL	STVR	G960 → G959... → G553 → G408 → ... → G002 → G001

5.5 Device power supply

The input signal level of CPV, RL, OE, STVR and STVL have to swing between VDD and VSS. The signal output level of start pulse (STVR or STVL) to the next stage cascaded device is VDD for H and VSS for L. The following conditions should be followed.

$V_{GH} - V_{EE} = 40V$ (max)

$V_{GH} - V_{SS} = 7\sim 35V$

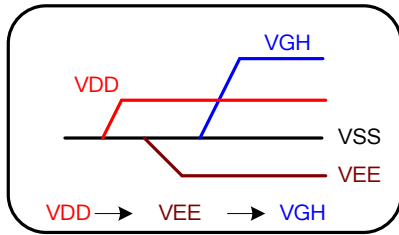

Power ON Sequence

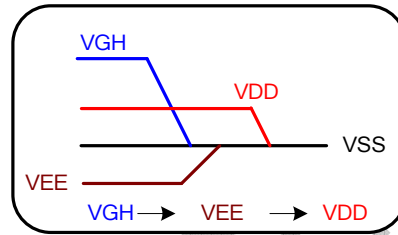

Power OFF Sequence

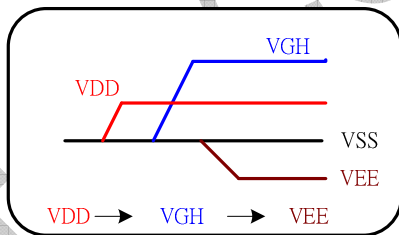
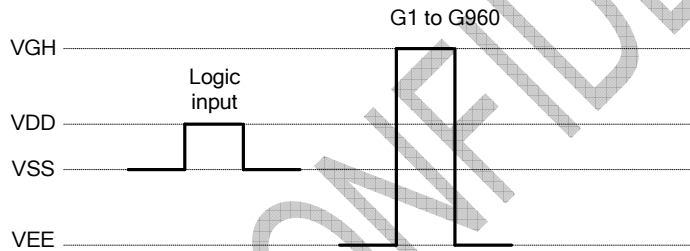

Power ON Sequence

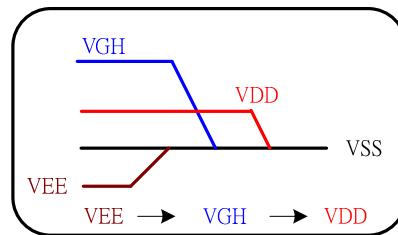

Power OFF Sequence

Note:

- (1). Input signals of CPV, XON, OE, RL, STVR & STVL, MODE.
- (2). The "High" level=VDD and "Low" level=VSS.

5.6 Power ON/OFF Sequence

To prevent the device damage from latch up, the power ON/OFF sequence shown below must be followed.

Power ON: VDD → VEE → VGH

Power OFF: VGH → VEE → VDD

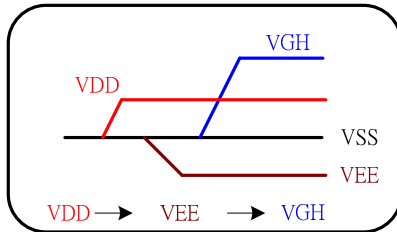

Power ON Sequence

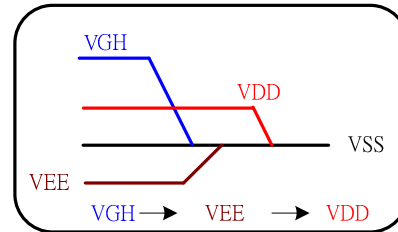

Power OFF Sequence

Power ON: VDD → VGH → VEE

Power OFF: VEE → VGH → VDD

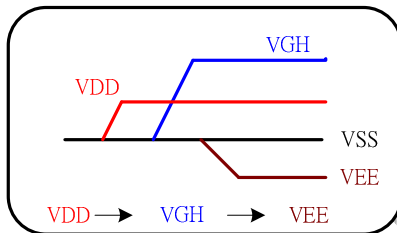

Power ON Sequence

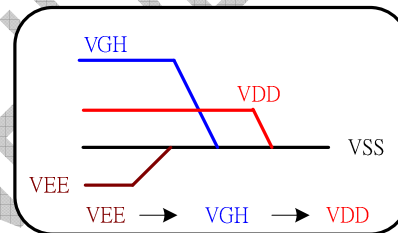

Power OFF Sequence

Power on sequence (VDD → VEE → VGH)

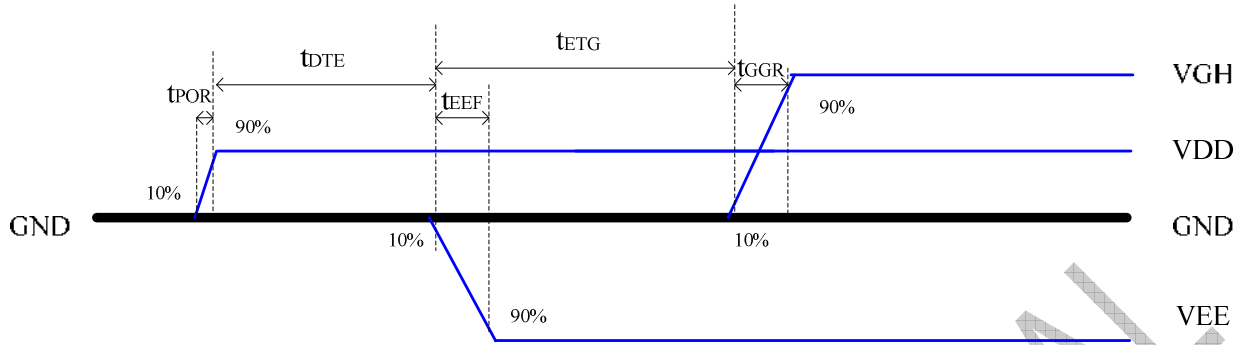

Power on sequence (VDD → VGH → VEE)

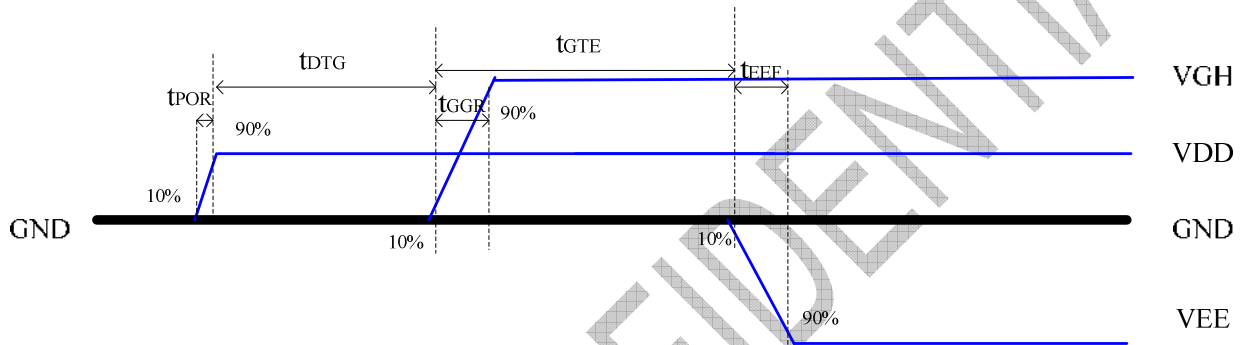

Power off sequence (VGH → VEE → VDD)

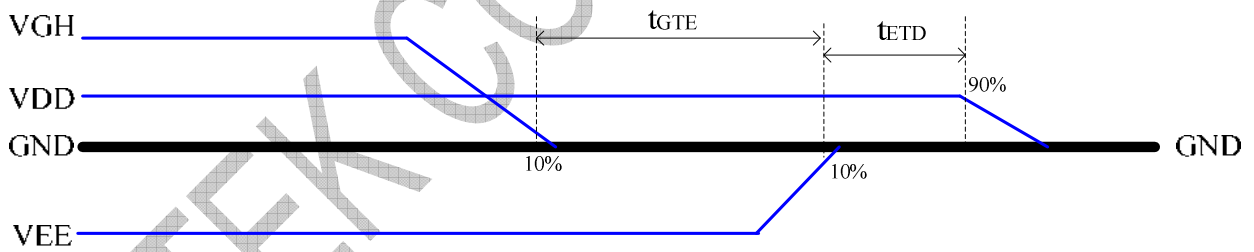

Power off sequence (VEE → VGH → VDD)

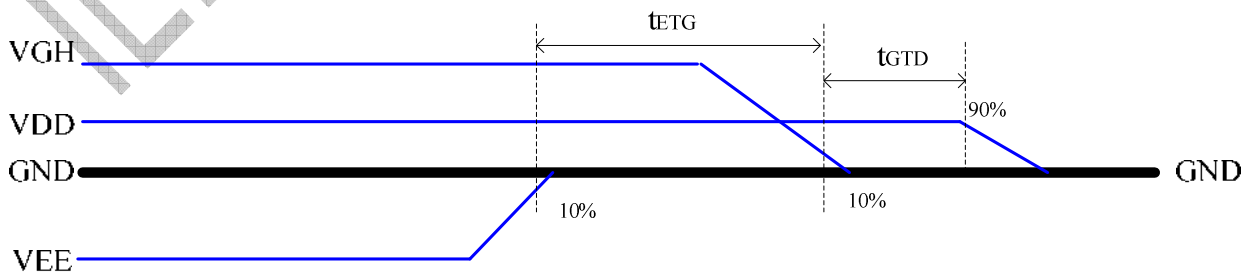

5.7 Start Pulse Input Limitation

The available start pulse is in the following diagram.

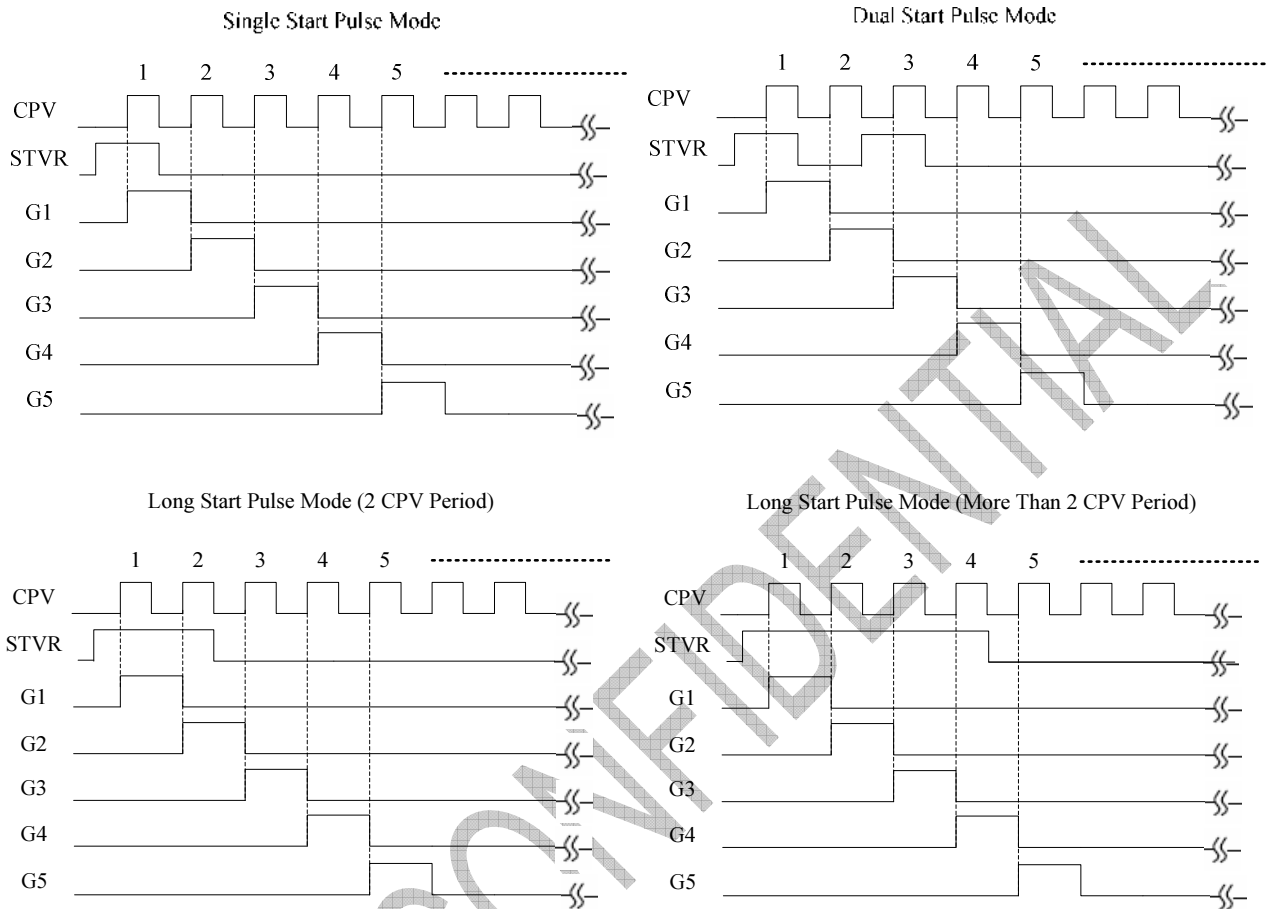

ILITEK CONFIDENTIAL

6. DC Characteristic

6.1 Absolute Maximum Rating

Parameter	Symbol	Rating			Unit
		Min	Typ	Max	
Power supply voltage (1)	VGH	-0.3	-	+42.0	V
Power supply voltage (2)	VDD	-0.3	-	+7.0	V
Power supply voltage (3)	VEE	VGH-42	-	+0.3	V
Input voltage	Vin	-0.3	-	VDD+0.3	V
Operating temperature	TOTG	-20	-	+85	°C
Storage temperature	TSTG	-55	-	+125	°C

Note:

- (1) All of the voltages listed above are with respect to VSS=0V.
- (2) Device is subject to be damaged permanently if stresses beyond those absolute maximum ratings listed above.
- (3) Condition VDD = 3.3V

6.2 Recommended operating conditions

(VSS=0V , TA= -20 ~ +85 °C)

Parameter	Symbol	Rating			Unit
		Min	Typ	Max	
Power supply voltage (1)	VGH	7	-	VEE+40	V
Power supply voltage (2)	VDD	2.7	3.3	3.6	V
Power supply voltage (3)	VEE	-20	-	-5	V
Power supply voltage (4)	VGH-VEE	12	-	40	V
Operation frequency	Fcpv	-	-	200	KHz
Operation temperature	Ta	-20	-	+85	°C

6.3 Electrical Characteristics

(VGH=25V, VEE=-15V, VDD=3.3V, VSS=0V, TA=25°C)

Parameter	Symbol	Condition	Rating			Unit	Application pin
			Min	Typ	Max		
Input H voltage	V _{IH}	-	0.7VDD	-	VDD	V	All input
Input L voltage	V _{IL}	-	VSS	-	0.3VDD	V	All input
Output H voltage	V _{OH}	I _{OH} =40μA	VDD-0.4	-	VDD	V	STVR,L
Output L voltage)	V _{OL}	I _{OL} =40μA	VSS	-	VSS+0.4	V	STVR,L
Output H resistance	R _{OH}	V _{OUT} = VGH-0.5V	-	-	1000	Ω	G0~961
Output L resistance	R _{OL}	V _{OUT} = VEE+0.5V	-	-	1000	Ω	G0~961
Input leakage current	I _{IN}	-	-5	-	±1	μA	Note (b)
Pull-up resistance	R _{IN}	V _{IN} =VDD	70	200	400	kΩ	XON, Mode ,SEL pin,when VDD=3.3V and TA=25°C
VDD operating current	I _{VDD}	Note (a)	-	-	T.B.D	μA	-
VGH operating current	I _{VGH}	Note (a)	-	-	T.B.D	μA	-
VEE operating current	I _{VEE}	Note (a)	-	-	T.B.D	μA	-

Note

(a) Power consumption with the following condition: Output no load, VGH=+25V, VEE= -15V, VDD=3.3V,

V_{IH}=VDD, V_{IL}=VSS, F_{CPV}=60 kHz, OE=V_{IL}, XON=V_{IH}, Mode= V_{IH}.

(b) All input except "XON" and "Mode" pin.

7. AC Characteristic

(VGH=25V, VEE=-15V, VDD=3.3V, VSS=0V, TA=25°C)

Parameter	Symbol	Condition	Spec			Unit
			Min	Typ	Max	
CPV period	tCPV	-	5	-	-	μs
CPV pulse width	tCPVH, tCPVL	50% duty cycle	2.5	-	-	μs
OE pulse width	tWOE	-	1	-	-	μs
XON pulse width	txon	-	10	-	-	μs
Data setup time	tSU	-	0.7	-	-	μs
Data hold time	tHD	-	0.7	-	-	μs
CPV to output delay time	tPD1	CL=200pF	-	-	1	μs
Start pulse output delay time	tPD2	CL=20pF	-	-	0.8	μs
OE to output delay time	tPD3	CL=200pF	-	-	0.8	μs
XON to output delay time	tPD4	CL=200pF	-	-	30	μs
Power-On Reset Slew Time	tpor	From 10% to 90% VDD	-	-		ms
VDD to VEE Time	tdte	From 10% VDD to 90% VEE	0			ms
VEE to VDD Time	tetd	From 10% VEE to 90% VDD	0			ms
VEE to VGH Time	tetg	From 10% VEE to 10% VGH	1			ms
VGH to VEE Time	tgte	From 10% VGH to 10% VEE	1			ms
VGH Rising Time	tggr (1)	From 10% to 90% VGH	teef			ms

Note: The measurement point for all of signals is 50% with input and output amplitude.

Note(1):teef=> VEE Falling Time, From 10% to 90% VEE

8. Timing Chart

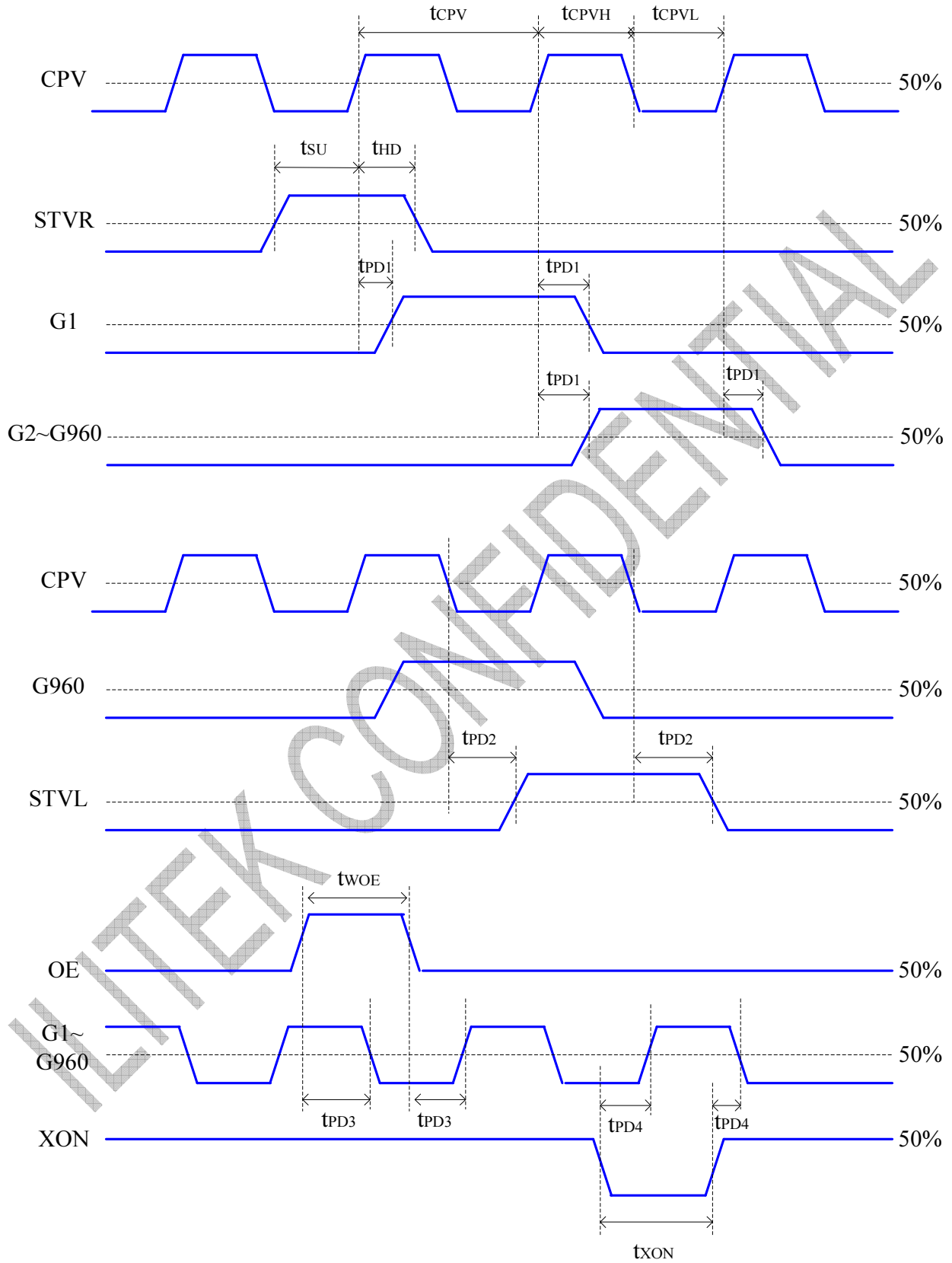

9. Pin Assignment (IC Face View)

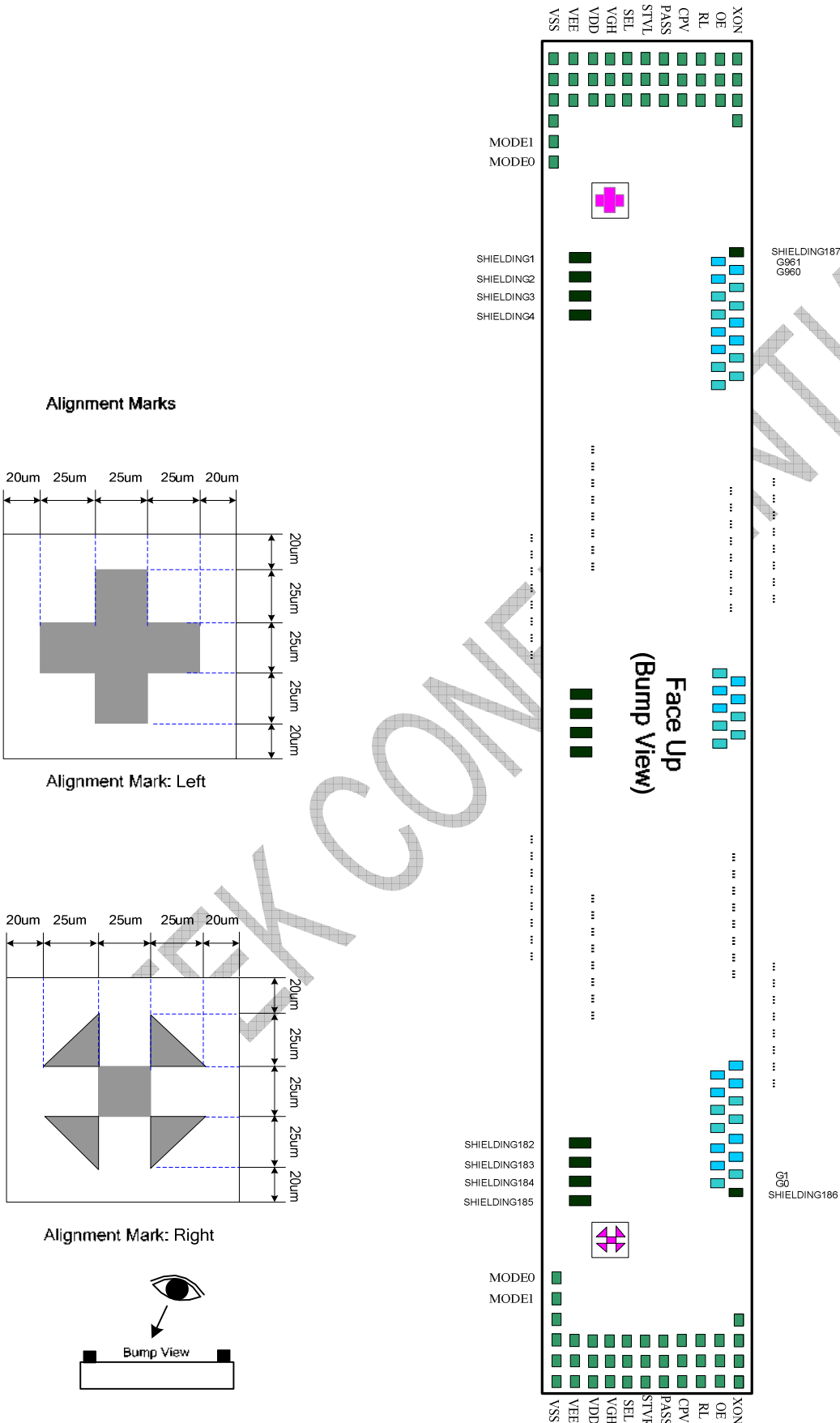

10. Pad Location

Pad No.	Name	X	Y	Pad No.	Name	X	Y	Pad	Name	X	Y
1	VSS	-10012	-262	61	SHIELDING55	-3800	-243	121	SHIELDING115	2200	-243
2	VSS	-9922	-262	62	SHIELDING56	-3700	-243	122	SHIELDING116	2300	-243
3	VSS	-9832	-262	63	SHIELDING57	-3600	-243	123	SHIELDING117	2400	-243
4	VSS	-9742	-262	64	SHIELDING58	-3500	-243	124	SHIELDING118	2500	-243
5	MODE1	-9652	-262	65	SHIELDING59	-3400	-243	125	SHIELDING119	2600	-243
6	MODE0	-9562	-262	66	SHIELDING60	-3300	-243	126	SHIELDING120	2700	-243
7	SHIELDING1	-9200	-243	67	SHIELDING61	-3200	-243	127	SHIELDING121	2800	-243
8	SHIELDING2	-9100	-243	68	SHIELDING62	-3100	-243	128	SHIELDING122	2900	-243
9	SHIELDING3	-9000	-243	69	SHIELDING63	-3000	-243	129	SHIELDING123	3000	-243
10	SHIELDING4	-8900	-243	70	SHIELDING64	-2900	-243	130	SHIELDING124	3100	-243
11	SHIELDING5	-8800	-243	71	SHIELDING65	-2800	-243	131	SHIELDING125	3200	-243
12	SHIELDING6	-8700	-243	72	SHIELDING66	-2700	-243	132	SHIELDING126	3300	-243
13	SHIELDING7	-8600	-243	73	SHIELDING67	-2600	-243	133	SHIELDING127	3400	-243
14	SHIELDING8	-8500	-243	74	SHIELDING68	-2500	-243	134	SHIELDING128	3500	-243
15	SHIELDING9	-8400	-243	75	SHIELDING69	-2400	-243	135	SHIELDING129	3600	-243
16	SHIELDING10	-8300	-243	76	SHIELDING70	-2300	-243	136	SHIELDING130	3700	-243
17	SHIELDING11	-8200	-243	77	SHIELDING71	-2200	-243	137	SHIELDING131	3800	-243
18	SHIELDING12	-8100	-243	78	SHIELDING72	-2100	-243	138	SHIELDING132	3900	-243
19	SHIELDING13	-8000	-243	79	SHIELDING73	-2000	-243	139	SHIELDING133	4000	-243
20	SHIELDING14	-7900	-243	80	SHIELDING74	-1900	-243	140	SHIELDING134	4100	-243
21	SHIELDING15	-7800	-243	81	SHIELDING75	-1800	-243	141	SHIELDING135	4200	-243
22	SHIELDING16	-7700	-243	82	SHIELDING76	-1700	-243	142	SHIELDING136	4300	-243
23	SHIELDING17	-7600	-243	83	SHIELDING77	-1600	-243	143	SHIELDING137	4400	-243
24	SHIELDING18	-7500	-243	84	SHIELDING78	-1500	-243	144	SHIELDING138	4500	-243
25	SHIELDING19	-7400	-243	85	SHIELDING79	-1400	-243	145	SHIELDING139	4600	-243
26	SHIELDING20	-7300	-243	86	SHIELDING80	-1300	-243	146	SHIELDING140	4700	-243
27	SHIELDING21	-7200	-243	87	SHIELDING81	-1200	-243	147	SHIELDING141	4800	-243
28	SHIELDING22	-7100	-243	88	SHIELDING82	-1100	-243	148	SHIELDING142	4900	-243
29	SHIELDING23	-7000	-243	89	SHIELDING83	-1000	-243	149	SHIELDING143	5000	-243
30	SHIELDING24	-6900	-243	90	SHIELDING84	-900	-243	150	SHIELDING144	5100	-243
31	SHIELDING25	-6800	-243	91	SHIELDING85	-800	-243	151	SHIELDING145	5200	-243
32	SHIELDING26	-6700	-243	92	SHIELDING86	-700	-243	152	SHIELDING146	5300	-243
33	SHIELDING27	-6600	-243	93	SHIELDING87	-600	-243	153	SHIELDING147	5400	-243
34	SHIELDING28	-6500	-243	94	SHIELDING88	-500	-243	154	SHIELDING148	5500	-243
35	SHIELDING29	-6400	-243	95	SHIELDING89	-400	-243	155	SHIELDING149	5600	-243
36	SHIELDING30	-6300	-243	96	SHIELDING90	-300	-243	156	SHIELDING150	5700	-243
37	SHIELDING31	-6200	-243	97	SHIELDING91	-200	-243	157	SHIELDING151	5800	-243
38	SHIELDING32	-6100	-243	98	SHIELDING92	-100	-243	158	SHIELDING152	5900	-243
39	SHIELDING33	-6000	-243	99	SHIELDING93	0	-243	159	SHIELDING153	6000	-243
40	SHIELDING34	-5900	-243	100	SHIELDING94	100	-243	160	SHIELDING154	6100	-243
41	SHIELDING35	-5800	-243	101	SHIELDING95	200	-243	161	SHIELDING155	6200	-243
42	SHIELDING36	-5700	-243	102	SHIELDING96	300	-243	162	SHIELDING156	6300	-243
43	SHIELDING37	-5600	-243	103	SHIELDING97	400	-243	163	SHIELDING157	6400	-243
44	SHIELDING38	-5500	-243	104	SHIELDING98	500	-243	164	SHIELDING158	6500	-243
45	SHIELDING39	-5400	-243	105	SHIELDING99	600	-243	165	SHIELDING159	6600	-243
46	SHIELDING40	-5300	-243	106	SHIELDING100	700	-243	166	SHIELDING160	6700	-243
47	SHIELDING41	-5200	-243	107	SHIELDING101	800	-243	167	SHIELDING161	6800	-243
48	SHIELDING42	-5100	-243	108	SHIELDING102	900	-243	168	SHIELDING162	6900	-243
49	SHIELDING43	-5000	-243	109	SHIELDING103	1000	-243	169	SHIELDING163	7000	-243
50	SHIELDING44	-4900	-243	110	SHIELDING104	1100	-243	170	SHIELDING164	7100	-243
51	SHIELDING45	-4800	-243	111	SHIELDING105	1200	-243	171	SHIELDING165	7200	-243
52	SHIELDING46	-4700	-243	112	SHIELDING106	1300	-243	172	SHIELDING166	7300	-243
53	SHIELDING47	-4600	-243	113	SHIELDING107	1400	-243	173	SHIELDING167	7400	-243
54	SHIELDING48	-4500	-243	114	SHIELDING108	1500	-243	174	SHIELDING168	7500	-243
55	SHIELDING49	-4400	-243	115	SHIELDING109	1600	-243	175	SHIELDING169	7600	-243
56	SHIELDING50	-4300	-243	116	SHIELDING110	1700	-243	176	SHIELDING170	7700	-243
57	SHIELDING51	-4200	-243	117	SHIELDING111	1800	-243	177	SHIELDING171	7800	-243
58	SHIELDING52	-4100	-243	118	SHIELDING112	1900	-243	178	SHIELDING172	7900	-243
59	SHIELDING53	-4000	-243	119	SHIELDING113	2000	-243	179	SHIELDING173	8000	-243
60	SHIELDING54	-3900	-243	120	SHIELDING114	2100	-243	180	SHIELDING174	8100	-243

Pad No.	Name	X	Y	Pad No.	Name	X	Y	Pad	Name	X	Y
181	SHIELDING175	8200	-243	241	G11	9380	125.5	301	G71	8180	125.5
182	SHIELDING176	8300	-243	242	G12	9360	235.5	302	G72	8160	235.5
183	SHIELDING177	8400	-243	243	G13	9340	125.5	303	G73	8140	125.5
184	SHIELDING178	8500	-243	244	G14	9320	235.5	304	G74	8120	235.5
185	SHIELDING179	8600	-243	245	G15	9300	125.5	305	G75	8100	125.5
186	SHIELDING180	8700	-243	246	G16	9280	235.5	306	G76	8080	235.5
187	SHIELDING181	8800	-243	247	G17	9260	125.5	307	G77	8060	125.5
188	SHIELDING182	8900	-243	248	G18	9240	235.5	308	G78	8040	235.5
189	SHIELDING183	9000	-243	249	G19	9220	125.5	309	G79	8020	125.5
190	SHIELDING184	9100	-243	250	G20	9200	235.5	310	G80	8000	235.5
191	SHIELDING185	9200	-243	251	G21	9180	125.5	311	G81	7980	125.5
192	MODE0	9562	-262	252	G22	9160	235.5	312	G82	7960	235.5
193	MODE1	9652	-262	253	G23	9140	125.5	313	G83	7940	125.5
194	VSS	9742	-262	254	G24	9120	235.5	314	G84	7920	235.5
195	VSS	9832	-262	255	G25	9100	125.5	315	G85	7900	125.5
196	VSS	9922	-262	256	G26	9080	235.5	316	G86	7880	235.5
197	VSS	10012	-262	257	G27	9060	125.5	317	G87	7860	125.5
198	VEE	9832	-208	258	G28	9040	235.5	318	G88	7840	235.5
199	VEE	9922	-208	259	G29	9020	125.5	319	G89	7820	125.5
200	VEE	10012	-208	260	G30	9000	235.5	320	G90	7800	235.5
201	VDD	9832	-156	261	G31	8980	125.5	321	G91	7780	125.5
202	VDD	9922	-156	262	G32	8960	235.5	322	G92	7760	235.5
203	VDD	10012	-156	263	G33	8940	125.5	323	G93	7740	125.5
204	VGH	9832	-104	264	G34	8920	235.5	324	G94	7720	235.5
205	VGH	9922	-104	265	G35	8900	125.5	325	G95	7700	125.5
206	VGH	10012	-104	266	G36	8880	235.5	326	G96	7680	235.5
207	SEL	9832	-52	267	G37	8860	125.5	327	G97	7660	125.5
208	SEL	9922	-52	268	G38	8840	235.5	328	G98	7640	235.5
209	SEL	10012	-52	269	G39	8820	125.5	329	G99	7620	125.5
210	STVR	9832	0	270	G40	8800	235.5	330	G100	7600	235.5
211	STVR	9922	0	271	G41	8780	125.5	331	G101	7580	125.5
212	STVR	10012	0	272	G42	8760	235.5	332	G102	7560	235.5
213	PASS	9832	52	273	G43	8740	125.5	333	G103	7540	125.5
214	PASS	9922	52	274	G44	8720	235.5	334	G104	7520	235.5
215	PASS	10012	52	275	G45	8700	125.5	335	G105	7500	125.5
216	CPV	9832	104	276	G46	8680	235.5	336	G106	7480	235.5
217	CPV	9922	104	277	G47	8660	125.5	337	G107	7460	125.5
218	CPV	10012	104	278	G48	8640	235.5	338	G108	7440	235.5
219	RL	9832	156	279	G49	8620	125.5	339	G109	7420	125.5
220	RL	9922	156	280	G50	8600	235.5	340	G110	7400	235.5
221	RL	10012	156	281	G51	8580	125.5	341	G111	7380	125.5
222	OE	9832	208	282	G52	8560	235.5	342	G112	7360	235.5
223	OE	9922	208	283	G53	8540	125.5	343	G113	7340	125.5
224	OE	10012	208	284	G54	8520	235.5	344	G114	7320	235.5
225	XON	9742	262	285	G55	8500	125.5	345	G115	7300	125.5
226	XON	9832	262	286	G56	8480	235.5	346	G116	7280	235.5
227	XON	9922	262	287	G57	8460	125.5	347	G117	7260	125.5
228	XON	10012	262	288	G58	8440	235.5	348	G118	7240	235.5
229	SHIELDING186	9640	235.5	289	G59	8420	125.5	349	G119	7220	125.5
230	G0	9600	235.5	290	G60	8400	235.5	350	G120	7200	235.5
231	G1	9580	125.5	291	G61	8380	125.5	351	G121	7180	125.5
232	G2	9560	235.5	292	G62	8360	235.5	352	G122	7160	235.5
233	G3	9540	125.5	293	G63	8340	125.5	353	G123	7140	125.5
234	G4	9520	235.5	294	G64	8320	235.5	354	G124	7120	235.5
235	G5	9500	125.5	295	G65	8300	125.5	355	G125	7100	125.5
236	G6	9480	235.5	296	G66	8280	235.5	356	G126	7080	235.5
237	G7	9460	125.5	297	G67	8260	125.5	357	G127	7060	125.5
238	G8	9440	235.5	298	G68	8240	235.5	358	G128	7040	235.5
239	G9	9420	125.5	299	G69	8220	125.5	359	G129	7020	125.5
240	G10	9400	235.5	300	G70	8200	235.5	360	G130	7000	235.5

Pad	Name	X	Y	Pad No.	Name	X	Y	Pad	Name	X	Y
361	G131	6980	125.5	421	G191	5780	125.5	481	G251	4580	125.5
362	G132	6960	235.5	422	G192	5760	235.5	482	G252	4560	235.5
363	G133	6940	125.5	423	G193	5740	125.5	483	G253	4540	125.5
364	G134	6920	235.5	424	G194	5720	235.5	484	G254	4520	235.5
365	G135	6900	125.5	425	G195	5700	125.5	485	G255	4500	125.5
366	G136	6880	235.5	426	G196	5680	235.5	486	G256	4480	235.5
367	G137	6860	125.5	427	G197	5660	125.5	487	G257	4460	125.5
368	G138	6840	235.5	428	G198	5640	235.5	488	G258	4440	235.5
369	G139	6820	125.5	429	G199	5620	125.5	489	G259	4420	125.5
370	G140	6800	235.5	430	G200	5600	235.5	490	G260	4400	235.5
371	G141	6780	125.5	431	G201	5580	125.5	491	G261	4380	125.5
372	G142	6760	235.5	432	G202	5560	235.5	492	G262	4360	235.5
373	G143	6740	125.5	433	G203	5540	125.5	493	G263	4340	125.5
374	G144	6720	235.5	434	G204	5520	235.5	494	G264	4320	235.5
375	G145	6700	125.5	435	G205	5500	125.5	495	G265	4300	125.5
376	G146	6680	235.5	436	G206	5480	235.5	496	G266	4280	235.5
377	G147	6660	125.5	437	G207	5460	125.5	497	G267	4260	125.5
378	G148	6640	235.5	438	G208	5440	235.5	498	G268	4240	235.5
379	G149	6620	125.5	439	G209	5420	125.5	499	G269	4220	125.5
380	G150	6600	235.5	440	G210	5400	235.5	500	G270	4200	235.5
381	G151	6580	125.5	441	G211	5380	125.5	501	G271	4180	125.5
382	G152	6560	235.5	442	G212	5360	235.5	502	G272	4160	235.5
383	G153	6540	125.5	443	G213	5340	125.5	503	G273	4140	125.5
384	G154	6520	235.5	444	G214	5320	235.5	504	G274	4120	235.5
385	G155	6500	125.5	445	G215	5300	125.5	505	G275	4100	125.5
386	G156	6480	235.5	446	G216	5280	235.5	506	G276	4080	235.5
387	G157	6460	125.5	447	G217	5260	125.5	507	G277	4060	125.5
388	G158	6440	235.5	448	G218	5240	235.5	508	G278	4040	235.5
389	G159	6420	125.5	449	G219	5220	125.5	509	G279	4020	125.5
390	G160	6400	235.5	450	G220	5200	235.5	510	G280	4000	235.5
391	G161	6380	125.5	451	G221	5180	125.5	511	G281	3980	125.5
392	G162	6360	235.5	452	G222	5160	235.5	512	G282	3960	235.5
393	G163	6340	125.5	453	G223	5140	125.5	513	G283	3940	125.5
394	G164	6320	235.5	454	G224	5120	235.5	514	G284	3920	235.5
395	G165	6300	125.5	455	G225	5100	125.5	515	G285	3900	125.5
396	G166	6280	235.5	456	G226	5080	235.5	516	G286	3880	235.5
397	G167	6260	125.5	457	G227	5060	125.5	517	G287	3860	125.5
398	G168	6240	235.5	458	G228	5040	235.5	518	G288	3840	235.5
399	G169	6220	125.5	459	G229	5020	125.5	519	G289	3820	125.5
400	G170	6200	235.5	460	G230	5000	235.5	520	G290	3800	235.5
401	G171	6180	125.5	461	G231	4980	125.5	521	G291	3780	125.5
402	G172	6160	235.5	462	G232	4960	235.5	522	G292	3760	235.5
403	G173	6140	125.5	463	G233	4940	125.5	523	G293	3740	125.5
404	G174	6120	235.5	464	G234	4920	235.5	524	G294	3720	235.5
405	G175	6100	125.5	465	G235	4900	125.5	525	G295	3700	125.5
406	G176	6080	235.5	466	G236	4880	235.5	526	G296	3680	235.5
407	G177	6060	125.5	467	G237	4860	125.5	527	G297	3660	125.5
408	G178	6040	235.5	468	G238	4840	235.5	528	G298	3640	235.5
409	G179	6020	125.5	469	G239	4820	125.5	529	G299	3620	125.5
410	G180	6000	235.5	470	G240	4800	235.5	530	G300	3600	235.5
411	G181	5980	125.5	471	G241	4780	125.5	531	G301	3580	125.5
412	G182	5960	235.5	472	G242	4760	235.5	532	G302	3560	235.5
413	G183	5940	125.5	473	G243	4740	125.5	533	G303	3540	125.5
414	G184	5920	235.5	474	G244	4720	235.5	534	G304	3520	235.5
415	G185	5900	125.5	475	G245	4700	125.5	535	G305	3500	125.5
416	G186	5880	235.5	476	G246	4680	235.5	536	G306	3480	235.5
417	G187	5860	125.5	477	G247	4660	125.5	537	G307	3460	125.5
418	G188	5840	235.5	478	G248	4640	235.5	538	G308	3440	235.5
419	G189	5820	125.5	479	G249	4620	125.5	539	G309	3420	125.5
420	G190	5800	235.5	480	G250	4600	235.5	540	G310	3400	235.5

Pad	Name	X	Y	Pad No.	Name	X	Y	Pad	Name	X	Y
541	G311	3380	125.5	601	G371	2180	125.5	661	G431	980	125.5
542	G312	3360	235.5	602	G372	2160	235.5	662	G432	960	235.5
543	G313	3340	125.5	603	G373	2140	125.5	663	G433	940	125.5
544	G314	3320	235.5	604	G374	2120	235.5	664	G434	920	235.5
545	G315	3300	125.5	605	G375	2100	125.5	665	G435	900	125.5
546	G316	3280	235.5	606	G376	2080	235.5	666	G436	880	235.5
547	G317	3260	125.5	607	G377	2060	125.5	667	G437	860	125.5
548	G318	3240	235.5	608	G378	2040	235.5	668	G438	840	235.5
549	G319	3220	125.5	609	G379	2020	125.5	669	G439	820	125.5
550	G320	3200	235.5	610	G380	2000	235.5	670	G440	800	235.5
551	G321	3180	125.5	611	G381	1980	125.5	671	G441	780	125.5
552	G322	3160	235.5	612	G382	1960	235.5	672	G442	760	235.5
553	G323	3140	125.5	613	G383	1940	125.5	673	G443	740	125.5
554	G324	3120	235.5	614	G384	1920	235.5	674	G444	720	235.5
555	G325	3100	125.5	615	G385	1900	125.5	675	G445	700	125.5
556	G326	3080	235.5	616	G386	1880	235.5	676	G446	680	235.5
557	G327	3060	125.5	617	G387	1860	125.5	677	G447	660	125.5
558	G328	3040	235.5	618	G388	1840	235.5	678	G448	640	235.5
559	G329	3020	125.5	619	G389	1820	125.5	679	G449	620	125.5
560	G330	3000	235.5	620	G390	1800	235.5	680	G450	600	235.5
561	G331	2980	125.5	621	G391	1780	125.5	681	G451	580	125.5
562	G332	2960	235.5	622	G392	1760	235.5	682	G452	560	235.5
563	G333	2940	125.5	623	G393	1740	125.5	683	G453	540	125.5
564	G334	2920	235.5	624	G394	1720	235.5	684	G454	520	235.5
565	G335	2900	125.5	625	G395	1700	125.5	685	G455	500	125.5
566	G336	2880	235.5	626	G396	1680	235.5	686	G456	480	235.5
567	G337	2860	125.5	627	G397	1660	125.5	687	G457	460	125.5
568	G338	2840	235.5	628	G398	1640	235.5	688	G458	440	235.5
569	G339	2820	125.5	629	G399	1620	125.5	689	G459	420	125.5
570	G340	2800	235.5	630	G400	1600	235.5	690	G460	400	235.5
571	G341	2780	125.5	631	G401	1580	125.5	691	G461	380	125.5
572	G342	2760	235.5	632	G402	1560	235.5	692	G462	360	235.5
573	G343	2740	125.5	633	G403	1540	125.5	693	G463	340	125.5
574	G344	2720	235.5	634	G404	1520	235.5	694	G464	320	235.5
575	G345	2700	125.5	635	G405	1500	125.5	695	G465	300	125.5
576	G346	2680	235.5	636	G406	1480	235.5	696	G466	280	235.5
577	G347	2660	125.5	637	G407	1460	125.5	697	G467	260	125.5
578	G348	2640	235.5	638	G408	1440	235.5	698	G468	240	235.5
579	G349	2620	125.5	639	G409	1420	125.5	699	G469	220	125.5
580	G350	2600	235.5	640	G410	1400	235.5	700	G470	200	235.5
581	G351	2580	125.5	641	G411	1380	125.5	701	G471	180	125.5
582	G352	2560	235.5	642	G412	1360	235.5	702	G472	160	235.5
583	G353	2540	125.5	643	G413	1340	125.5	703	G473	140	125.5
584	G354	2520	235.5	644	G414	1320	235.5	704	G474	120	235.5
585	G355	2500	125.5	645	G415	1300	125.5	705	G475	100	125.5
586	G356	2480	235.5	646	G416	1280	235.5	706	G476	80	235.5
587	G357	2460	125.5	647	G417	1260	125.5	707	G477	60	125.5
588	G358	2440	235.5	648	G418	1240	235.5	708	G478	40	235.5
589	G359	2420	125.5	649	G419	1220	125.5	709	G479	20	125.5
590	G360	2400	235.5	650	G420	1200	235.5	710	G480	0	235.5
591	G361	2380	125.5	651	G421	1180	125.5	711	G481	-20	125.5
592	G362	2360	235.5	652	G422	1160	235.5	712	G482	-40	235.5
593	G363	2340	125.5	653	G423	1140	125.5	713	G483	-60	125.5
594	G364	2320	235.5	654	G424	1120	235.5	714	G484	-80	235.5
595	G365	2300	125.5	655	G425	1100	125.5	715	G485	-100	125.5
596	G366	2280	235.5	656	G426	1080	235.5	716	G486	-120	235.5
597	G367	2260	125.5	657	G427	1060	125.5	717	G487	-140	125.5
598	G368	2240	235.5	658	G428	1040	235.5	718	G488	-160	235.5
599	G369	2220	125.5	659	G429	1020	125.5	719	G489	-180	125.5
600	G370	2200	235.5	660	G430	1000	235.5	720	G490	-200	235.5

Pad	Name	X	Y	Pad No.	Name	X	Y	Pad	Name	X	Y
721	G491	-220	125.5	781	G551	-1420	125.5	841	G611	-2620	125.5
722	G492	-240	235.5	782	G552	-1440	235.5	842	G612	-2640	235.5
723	G493	-260	125.5	783	G553	-1460	125.5	843	G613	-2660	125.5
724	G494	-280	235.5	784	G554	-1480	235.5	844	G614	-2680	235.5
725	G495	-300	125.5	785	G555	-1500	125.5	845	G615	-2700	125.5
726	G496	-320	235.5	786	G556	-1520	235.5	846	G616	-2720	235.5
727	G497	-340	125.5	787	G557	-1540	125.5	847	G617	-2740	125.5
728	G498	-360	235.5	788	G558	-1560	235.5	848	G618	-2760	235.5
729	G499	-380	125.5	789	G559	-1580	125.5	849	G619	-2780	125.5
730	G500	-400	235.5	790	G560	-1600	235.5	850	G620	-2800	235.5
731	G501	-420	125.5	791	G561	-1620	125.5	851	G621	-2820	125.5
732	G502	-440	235.5	792	G562	-1640	235.5	852	G622	-2840	235.5
733	G503	-460	125.5	793	G563	-1660	125.5	853	G623	-2860	125.5
734	G504	-480	235.5	794	G564	-1680	235.5	854	G624	-2880	235.5
735	G505	-500	125.5	795	G565	-1700	125.5	855	G625	-2900	125.5
736	G506	-520	235.5	796	G566	-1720	235.5	856	G626	-2920	235.5
737	G507	-540	125.5	797	G567	-1740	125.5	857	G627	-2940	125.5
738	G508	-560	235.5	798	G568	-1760	235.5	858	G628	-2960	235.5
739	G509	-580	125.5	799	G569	-1780	125.5	859	G629	-2980	125.5
740	G510	-600	235.5	800	G570	-1800	235.5	860	G630	-3000	235.5
741	G511	-620	125.5	801	G571	-1820	125.5	861	G631	-3020	125.5
742	G512	-640	235.5	802	G572	-1840	235.5	862	G632	-3040	235.5
743	G513	-660	125.5	803	G573	-1860	125.5	863	G633	-3060	125.5
744	G514	-680	235.5	804	G574	-1880	235.5	864	G634	-3080	235.5
745	G515	-700	125.5	805	G575	-1900	125.5	865	G635	-3100	125.5
746	G516	-720	235.5	806	G576	-1920	235.5	866	G636	-3120	235.5
747	G517	-740	125.5	807	G577	-1940	125.5	867	G637	-3140	125.5
748	G518	-760	235.5	808	G578	-1960	235.5	868	G638	-3160	235.5
749	G519	-780	125.5	809	G579	-1980	125.5	869	G639	-3180	125.5
750	G520	-800	235.5	810	G580	-2000	235.5	870	G640	-3200	235.5
751	G521	-820	125.5	811	G581	-2020	125.5	871	G641	-3220	125.5
752	G522	-840	235.5	812	G582	-2040	235.5	872	G642	-3240	235.5
753	G523	-860	125.5	813	G583	-2060	125.5	873	G643	-3260	125.5
754	G524	-880	235.5	814	G584	-2080	235.5	874	G644	-3280	235.5
755	G525	-900	125.5	815	G585	-2100	125.5	875	G645	-3300	125.5
756	G526	-920	235.5	816	G586	-2120	235.5	876	G646	-3320	235.5
757	G527	-940	125.5	817	G587	-2140	125.5	877	G647	-3340	125.5
758	G528	-960	235.5	818	G588	-2160	235.5	878	G648	-3360	235.5
759	G529	-980	125.5	819	G589	-2180	125.5	879	G649	-3380	125.5
760	G530	-1000	235.5	820	G590	-2200	235.5	880	G650	-3400	235.5
761	G531	-1020	125.5	821	G591	-2220	125.5	881	G651	-3420	125.5
762	G532	-1040	235.5	822	G592	-2240	235.5	882	G652	-3440	235.5
763	G533	-1060	125.5	823	G593	-2260	125.5	883	G653	-3460	125.5
764	G534	-1080	235.5	824	G594	-2280	235.5	884	G654	-3480	235.5
765	G535	-1100	125.5	825	G595	-2300	125.5	885	G655	-3500	125.5
766	G536	-1120	235.5	826	G596	-2320	235.5	886	G656	-3520	235.5
767	G537	-1140	125.5	827	G597	-2340	125.5	887	G657	-3540	125.5
768	G538	-1160	235.5	828	G598	-2360	235.5	888	G658	-3560	235.5
769	G539	-1180	125.5	829	G599	-2380	125.5	889	G659	-3580	125.5
770	G540	-1200	235.5	830	G600	-2400	235.5	890	G660	-3600	235.5
771	G541	-1220	125.5	831	G601	-2420	125.5	891	G661	-3620	125.5
772	G542	-1240	235.5	832	G602	-2440	235.5	892	G662	-3640	235.5
773	G543	-1260	125.5	833	G603	-2460	125.5	893	G663	-3660	125.5
774	G544	-1280	235.5	834	G604	-2480	235.5	894	G664	-3680	235.5
775	G545	-1300	125.5	835	G605	-2500	125.5	895	G665	-3700	125.5
776	G546	-1320	235.5	836	G606	-2520	235.5	896	G666	-3720	235.5
777	G547	-1340	125.5	837	G607	-2540	125.5	897	G667	-3740	125.5
778	G548	-1360	235.5	838	G608	-2560	235.5	898	G668	-3760	235.5
779	G549	-1380	125.5	839	G609	-2580	125.5	899	G669	-3780	125.5
780	G550	-1400	235.5	840	G610	-2600	235.5	900	G670	-3800	235.5

Pad	Name	X	Y	Pad No.	Name	X	Y	Pad	Name	X	Y
901	G671	-3820	125.5	961	G731	-5020	125.5	1021	G791	-6220	125.5
902	G672	-3840	235.5	962	G732	-5040	235.5	1022	G792	-6240	235.5
903	G673	-3860	125.5	963	G733	-5060	125.5	1023	G793	-6260	125.5
904	G674	-3880	235.5	964	G734	-5080	235.5	1024	G794	-6280	235.5
905	G675	-3900	125.5	965	G735	-5100	125.5	1025	G795	-6300	125.5
906	G676	-3920	235.5	966	G736	-5120	235.5	1026	G796	-6320	235.5
907	G677	-3940	125.5	967	G737	-5140	125.5	1027	G797	-6340	125.5
908	G678	-3960	235.5	968	G738	-5160	235.5	1028	G798	-6360	235.5
909	G679	-3980	125.5	969	G739	-5180	125.5	1029	G799	-6380	125.5
910	G680	-4000	235.5	970	G740	-5200	235.5	1030	G800	-6400	235.5
911	G681	-4020	125.5	971	G741	-5220	125.5	1031	G801	-6420	125.5
912	G682	-4040	235.5	972	G742	-5240	235.5	1032	G802	-6440	235.5
913	G683	-4060	125.5	973	G743	-5260	125.5	1033	G803	-6460	125.5
914	G684	-4080	235.5	974	G744	-5280	235.5	1034	G804	-6480	235.5
915	G685	-4100	125.5	975	G745	-5300	125.5	1035	G805	-6500	125.5
916	G686	-4120	235.5	976	G746	-5320	235.5	1036	G806	-6520	235.5
917	G687	-4140	125.5	977	G747	-5340	125.5	1037	G807	-6540	125.5
918	G688	-4160	235.5	978	G748	-5360	235.5	1038	G808	-6560	235.5
919	G689	-4180	125.5	979	G749	-5380	125.5	1039	G809	-6580	125.5
920	G690	-4200	235.5	980	G750	-5400	235.5	1040	G810	-6600	235.5
921	G691	-4220	125.5	981	G751	-5420	125.5	1041	G811	-6620	125.5
922	G692	-4240	235.5	982	G752	-5440	235.5	1042	G812	-6640	235.5
923	G693	-4260	125.5	983	G753	-5460	125.5	1043	G813	-6660	125.5
924	G694	-4280	235.5	984	G754	-5480	235.5	1044	G814	-6680	235.5
925	G695	-4300	125.5	985	G755	-5500	125.5	1045	G815	-6700	125.5
926	G696	-4320	235.5	986	G756	-5520	235.5	1046	G816	-6720	235.5
927	G697	-4340	125.5	987	G757	-5540	125.5	1047	G817	-6740	125.5
928	G698	-4360	235.5	988	G758	-5560	235.5	1048	G818	-6760	235.5
929	G699	-4380	125.5	989	G759	-5580	125.5	1049	G819	-6780	125.5
930	G700	-4400	235.5	990	G760	-5600	235.5	1050	G820	-6800	235.5
931	G701	-4420	125.5	991	G761	-5620	125.5	1051	G821	-6820	125.5
932	G702	-4440	235.5	992	G762	-5640	235.5	1052	G822	-6840	235.5
933	G703	-4460	125.5	993	G763	-5660	125.5	1053	G823	-6860	125.5
934	G704	-4480	235.5	994	G764	-5680	235.5	1054	G824	-6880	235.5
935	G705	-4500	125.5	995	G765	-5700	125.5	1055	G825	-6900	125.5
936	G706	-4520	235.5	996	G766	-5720	235.5	1056	G826	-6920	235.5
937	G707	-4540	125.5	997	G767	-5740	125.5	1057	G827	-6940	125.5
938	G708	-4560	235.5	998	G768	-5760	235.5	1058	G828	-6960	235.5
939	G709	-4580	125.5	999	G769	-5780	125.5	1059	G829	-6980	125.5
940	G710	-4600	235.5	1000	G770	-5800	235.5	1060	G830	-7000	235.5
941	G711	-4620	125.5	1001	G771	-5820	125.5	1061	G831	-7020	125.5
942	G712	-4640	235.5	1002	G772	-5840	235.5	1062	G832	-7040	235.5
943	G713	-4660	125.5	1003	G773	-5860	125.5	1063	G833	-7060	125.5
944	G714	-4680	235.5	1004	G774	-5880	235.5	1064	G834	-7080	235.5
945	G715	-4700	125.5	1005	G775	-5900	125.5	1065	G835	-7100	125.5
946	G716	-4720	235.5	1006	G776	-5920	235.5	1066	G836	-7120	235.5
947	G717	-4740	125.5	1007	G777	-5940	125.5	1067	G837	-7140	125.5
948	G718	-4760	235.5	1008	G778	-5960	235.5	1068	G838	-7160	235.5
949	G719	-4780	125.5	1009	G779	-5980	125.5	1069	G839	-7180	125.5
950	G720	-4800	235.5	1010	G780	-6000	235.5	1070	G840	-7200	235.5
951	G721	-4820	125.5	1011	G781	-6020	125.5	1071	G841	-7220	125.5
952	G722	-4840	235.5	1012	G782	-6040	235.5	1072	G842	-7240	235.5
953	G723	-4860	125.5	1013	G783	-6060	125.5	1073	G843	-7260	125.5
954	G724	-4880	235.5	1014	G784	-6080	235.5	1074	G844	-7280	235.5
955	G725	-4900	125.5	1015	G785	-6100	125.5	1075	G845	-7300	125.5
956	G726	-4920	235.5	1016	G786	-6120	235.5	1076	G846	-7320	235.5
957	G727	-4940	125.5	1017	G787	-6140	125.5	1077	G847	-7340	125.5
958	G728	-4960	235.5	1018	G788	-6160	235.5	1078	G848	-7360	235.5
959	G729	-4980	125.5	1019	G789	-6180	125.5	1079	G849	-7380	125.5
960	G730	-5000	235.5	1020	G790	-6200	235.5	1080	G850	-7400	235.5

Pad	Name	X	Y	Pad No.	Name	X	Y	Pad	Name	X	Y
1081	G851	-7420	125.5	1141	G911	-8620	125.5	1201	RL	-9922	156
1082	G852	-7440	235.5	1142	G912	-8640	235.5	1202	RL	-10012	156
1083	G853	-7460	125.5	1143	G913	-8660	125.5	1203	CPV	-9832	104
1084	G854	-7480	235.5	1144	G914	-8680	235.5	1204	CPV	-9922	104
1085	G855	-7500	125.5	1145	G915	-8700	125.5	1205	CPV	-10012	104
1086	G856	-7520	235.5	1146	G916	-8720	235.5	1206	PASS	-9832	52
1087	G857	-7540	125.5	1147	G917	-8740	125.5	1207	PASS	-9922	52
1088	G858	-7560	235.5	1148	G918	-8760	235.5	1208	PASS	-10012	52
1089	G859	-7580	125.5	1149	G919	-8780	125.5	1209	STVL	-9832	0
1090	G860	-7600	235.5	1150	G920	-8800	235.5	1210	STVL	-9922	0
1091	G861	-7620	125.5	1151	G921	-8820	125.5	1211	STVL	-10012	0
1092	G862	-7640	235.5	1152	G922	-8840	235.5	1212	SEL	-9832	-52
1093	G863	-7660	125.5	1153	G923	-8860	125.5	1213	SEL	-9922	-52
1094	G864	-7680	235.5	1154	G924	-8880	235.5	1214	SEL	-10012	-52
1095	G865	-7700	125.5	1155	G925	-8900	125.5	1215	VGH	-9832	-104
1096	G866	-7720	235.5	1156	G926	-8920	235.5	1216	VGH	-9922	-104
1097	G867	-7740	125.5	1157	G927	-8940	125.5	1217	VGH	-10012	-104
1098	G868	-7760	235.5	1158	G928	-8960	235.5	1218	VDD	-9832	-156
1099	G869	-7780	125.5	1159	G929	-8980	125.5	1219	VDD	-9922	-156
1100	G870	-7800	235.5	1160	G930	-9000	235.5	1220	VDD	-10012	-156
1101	G871	-7820	125.5	1161	G931	-9020	125.5	1221	VEE	-9832	-208
1102	G872	-7840	235.5	1162	G932	-9040	235.5	1222	VEE	-9922	-208
1103	G873	-7860	125.5	1163	G933	-9060	125.5	1223	VEE	-10012	-208
1104	G874	-7880	235.5	1164	G934	-9080	235.5	1224	AL MARK L	-9383.5	-220.5
1105	G875	-7900	125.5	1165	G935	-9100	125.5	1225	AL MARK R	9383.5	-220.5
1106	G876	-7920	235.5	1166	G936	-9120	235.5				
1107	G877	-7940	125.5	1167	G937	-9140	125.5				
1108	G878	-7960	235.5	1168	G938	-9160	235.5				
1109	G879	-7980	125.5	1169	G939	-9180	125.5				
1110	G880	-8000	235.5	1170	G940	-9200	235.5				
1111	G881	-8020	125.5	1171	G941	-9220	125.5				
1112	G882	-8040	235.5	1172	G942	-9240	235.5				
1113	G883	-8060	125.5	1173	G943	-9260	125.5				
1114	G884	-8080	235.5	1174	G944	-9280	235.5				
1115	G885	-8100	125.5	1175	G945	-9300	125.5				
1116	G886	-8120	235.5	1176	G946	-9320	235.5				
1117	G887	-8140	125.5	1177	G947	-9340	125.5				
1118	G888	-8160	235.5	1178	G948	-9360	235.5				
1119	G889	-8180	125.5	1179	G949	-9380	125.5				
1120	G890	-8200	235.5	1180	G950	-9400	235.5				
1121	G891	-8220	125.5	1181	G951	-9420	125.5				
1122	G892	-8240	235.5	1182	G952	-9440	235.5				
1123	G893	-8260	125.5	1183	G953	-9460	125.5				
1124	G894	-8280	235.5	1184	G954	-9480	235.5				
1125	G895	-8300	125.5	1185	G955	-9500	125.5				
1126	G896	-8320	235.5	1186	G956	-9520	235.5				
1127	G897	-8340	125.5	1187	G957	-9540	125.5				
1128	G898	-8360	235.5	1188	G958	-9560	235.5				
1129	G899	-8380	125.5	1189	G959	-9580	125.5				
1130	G900	-8400	235.5	1190	G960	-9600	235.5				
1131	G901	-8420	125.5	1191	G961	-9620	125.5				
1132	G902	-8440	235.5	1192	SHIELDING187	-9640	235.5				
1133	G903	-8460	125.5	1193	XON	-9742	262				
1134	G904	-8480	235.5	1194	XON	-9832	262				
1135	G905	-8500	125.5	1195	XON	-9922	262				
1136	G906	-8520	235.5	1196	XON	-10012	262				
1137	G907	-8540	125.5	1197	OE	-9832	208				
1138	G908	-8560	235.5	1198	OE	-9922	208				
1139	G909	-8580	125.5	1199	OE	-10012	208				
1140	G910	-8600	235.5	1200	RL	-9832	156				

11. Bump Mask Information

- Chip size: 670 × 20208

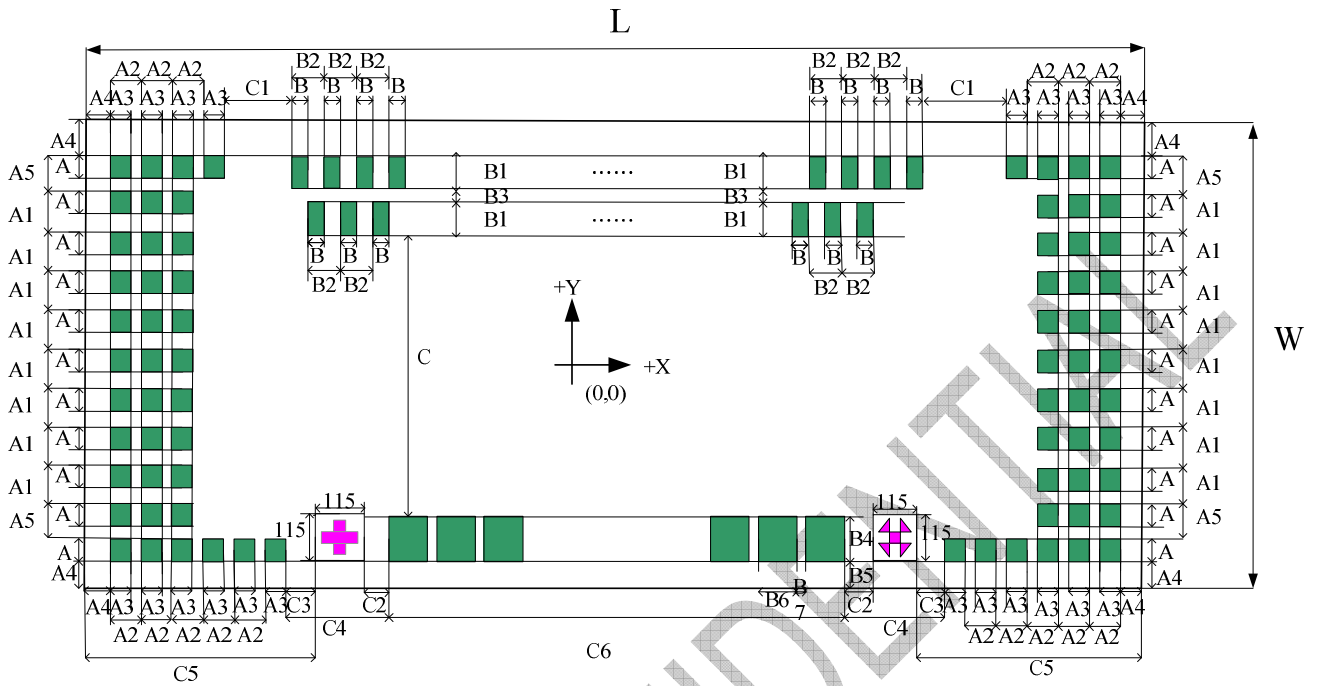

Symbol	Dimensions(um)	Symbol	Dimensions(um)	Symbol	Dimensions(um)
A	32	B2	40	C2	86
A1	52	B3	25	C3	86
A2	90	B4	70	C4	287
A3	70	B5	57	C5	663
A4	57	B6	80	C6	18480
A5	54	B7	20	L	20208
B	20	C	291	W	670
B1	85	C1	57		

Note: Chip dimension include scribe line

Alignment Mark type and coordinate

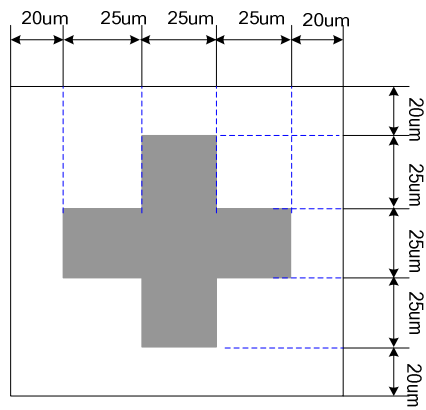

Alignment Mark: Left

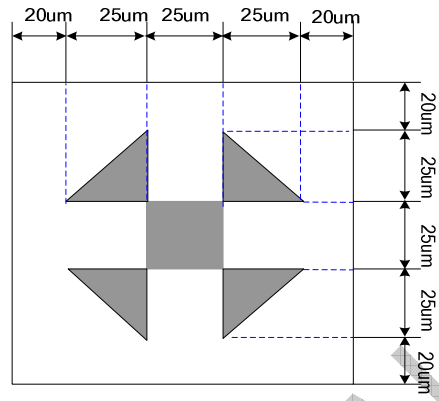

Alignment Mark: Right

LITEK CONFIDENTIAL

12. Revision History

Version No.	Date	Page	Description
0.01	2009/05/12	All	New set up
0.02	2009/06/19	4.8.25	MODE Pull high & Bump Mask Information
0.03	2009/06/25	17.25	Die size & Pin Assignment(STVR&STVL)
0.04	2010/04/07	10~12	Modify Power Sequence
0.05	2010/10/01	26	Bump Mask Information

LITEK CONFIDENTIAL