



145 Royal Crest Court Unit 42 Markham, ON, Canada L3R 9Z4
Tel: 905-477-1166 Fax: 905-477-1782 <http://www.orientdisplay.com>

MODULE NO.: AMG12864R2-G-W6WFDW
DOC.REVISION: 00

Customer Approval:

--

	SIGNATURE	DATE
PREPARED BY (RD ENGINEER)		
PREPARED BY (QA ENGINEER)		
CHECKED BY		
APPROVED BY		

DOCUMENT REVISION HISTORY

Version	DATE	DESCRIPTION	CHANGED BY
00	Oct-14-2009	First issue	Chen

CONTENTS

1. Functions & Features	2
2. Mechanical specifications	2
3. Block diagram	2
4. Dimensional outline	3
5. LCD Driving voltage generator and bias reference circuit	4
6. Pin description	5
7. Maximum absolute limit	6
8. Electrical characteristics	7
9. Timing characteristics	8~10
10. Reset timing	10
11. Control and display command	11
12. Backlight characteristics	12
13. Electro-Optical characteristics	12
14. Precaution for using LCD/LCM	13/14
15. LCM test criteria	15~24

1. FUNCTIONS & FEATURES

- | | |
|--|---------------------------------------|
| 1.1. Format | : 128x64 Dots |
| 1.2. LCD mode | : FSTN / Positive/ Transflective Mode |
| 1.3. Viewing direction | : 6 o'clock |
| 1.4. Driving scheme | : 1/65 Duty cycle, 1/9 Bias |
| 1.5. Power supply voltage (V _{DD}) | : 3.0V |
| 1.6. LCD driving voltage (V _{LCD}) | : 9.0V (Reference voltage) |
| 1.7. Operation temp | : -20~70°C |
| 1.8. Storage temp | : -30~80°C |
| 1.9. Backlight color | : Edge White |
| 1.10. RoHS compliant. | |

2. MECHANICAL SPECIFICATIONS

- | | |
|-------------------|---|
| 2.1. Module size | : 45.0mm (L)*40.0+50.0(FPC)mm (W)*7.2mm (H) |
| 2.2. Viewing area | : 37.0mm (L)*28.0mm (W) |
| 2.3. Dot pitch | : 0.282mm (L)*0.36mm (W) |
| 2.4. Dot size | : 0.252mm (L)*0.33mm (W) |
| 2.5. Weight | : Approx. |

3. BLOCK DIAGRAM

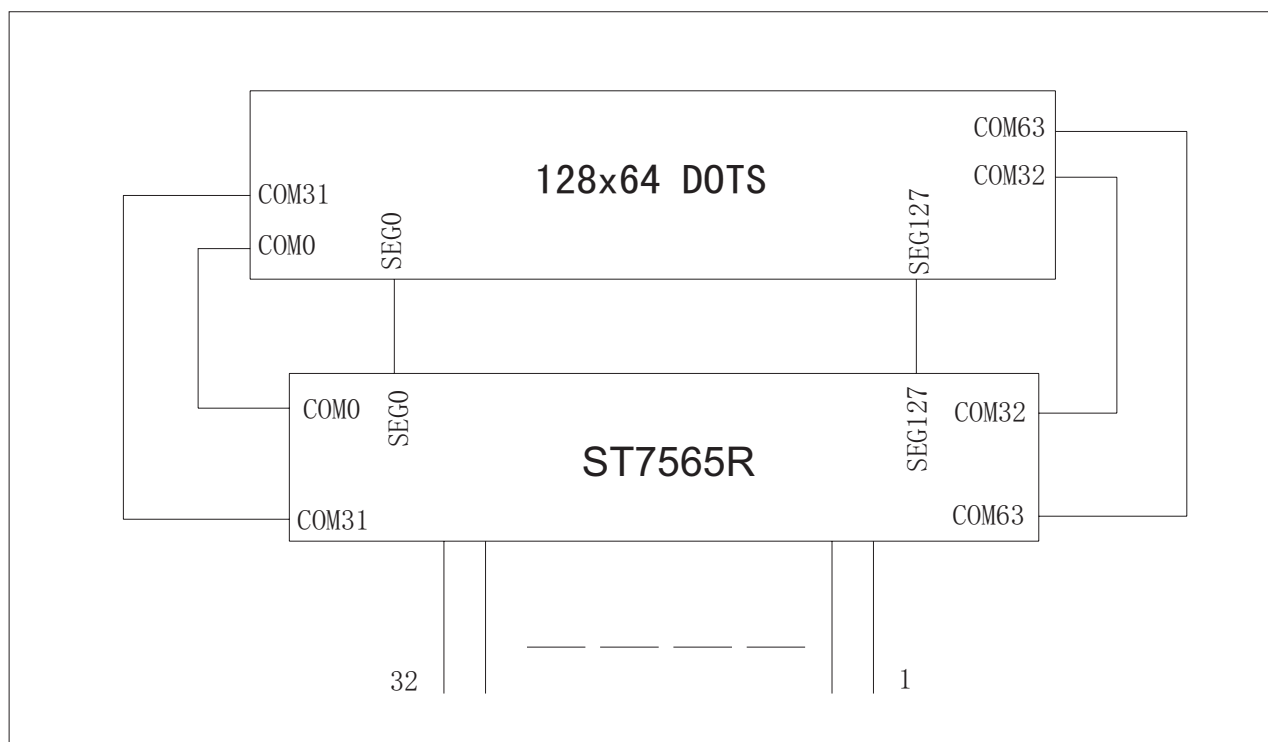
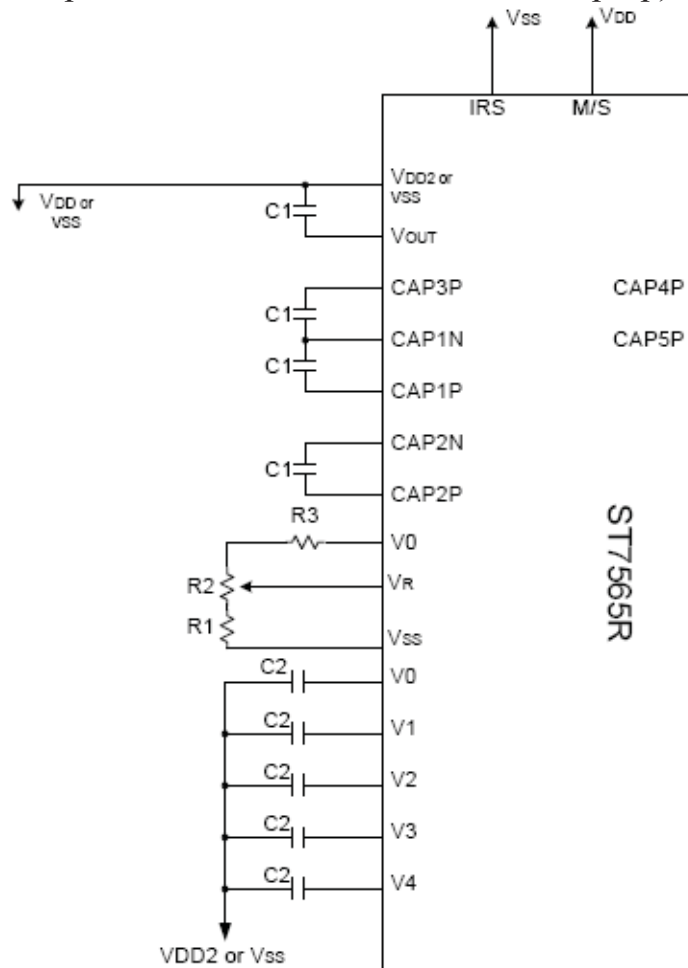

Figure 1. Block diagram

5. LCD Driving voltage generator and bias reference circuit

When the voltage regulator internal resistor is not used.
(Example where $V_{DD2}=V_{DD}$, with 4× step-up)



Item	Set value	units
c1	1.0 to 4.7	uF
c2	0.1 to 4.7	uF

C1 and C2 are determined by the size of the LCD being driven

* 1. Because the VR terminal input impedance is high, use short leads and shielded lines.

* 2. C1 and C2 are determined by the size of the LCD being driven. Select a value that will stabilize the liquid crystal drive voltage.

Example of the Process by which to Determine the Settings:

- Turn the voltage regulator circuit and voltage follower circuit ON and supply a voltage to VOUT from the outside.
- Determine C2 by displaying an LCD pattern with a heavy load (such as horizontal stripes) and selecting a C2 that stabilizes the liquid crystal drive voltages (V0 to V4). Note that all C2 capacitors must have the same capacitance value.
- Next turn all the power supplies ON and determine C1.

6. PIN DESCRIPTION

1	IRS	This terminal selects the resistors for the V0 voltage level adjustment. IRS = "H", Use the internal resistors IRS = "L", Do not use the internal resistors
2	HPMB	This is the power control terminal for the power supply circuit for liquid crystal drive. /HPM = "H": Normal mode /HPM = "L": High power mode (suggested)
3	PSB	This is the parallel data input/4-line SPI data input switch terminal. P/S = "H": Parallel data input. P/S = "L": 4-line SPI data input.
4	C86	This is the MPU interface switch terminal C86 = "H": 6800 Series MPU interface C86 = "L": 8080 Series MPU interface
5	VR	Voltage adjustment pad. Applies voltage between V0 and VSS using a resistive divider.
6~10	V0,V1,V2,V3,V4	LCD driver supplies voltages.
11~16	CAP4+, CAP2-, CAP2+, CAP1+, CAP1-, CAP3+	DC/DC voltage converter.
17	VOUT	DC/DC voltage converter. Connect a capacitor between this terminal and VSS or VDD
18	VSS	Power ground
19	VDD	Power supply for logic(+3.0V)
20~27	D7~D0	Data bus lines
28	RD(E)	Enable signal
29	WR(RW)	Write signal
30	A0	This is connected to the least significant bit of the normal MPU address bus, and it determines whether the data bits are data or a command
31	/RES	The RESET signal
32	/CS1	This is the chip select signal

7. MAXIMUM ABSOLUTE LIMIT

Maximum Ratings (Voltage Reference to VSS)(for IC)

Unless otherwise noted, $V_{SS} = 0V$

Table 17

Parameter		Symbol	Conditions	Unit
Power Supply Voltage		VDD	-0.3 ~ 3.6	V
Power supply voltage (VDD standard)		VDD2	-0.3 ~ 3.6	V
Power supply voltage (VDD standard)		V0, VOUT	-0.3 ~ 13.5	V
Power supply voltage (VDD standard)		V1, V2, V3, V4	-0.3 to V0	V
Operating temperature		TOPR	-30 to +85	°C
Storage temperature	Bare chip	TSTR	-65 to +150	°C

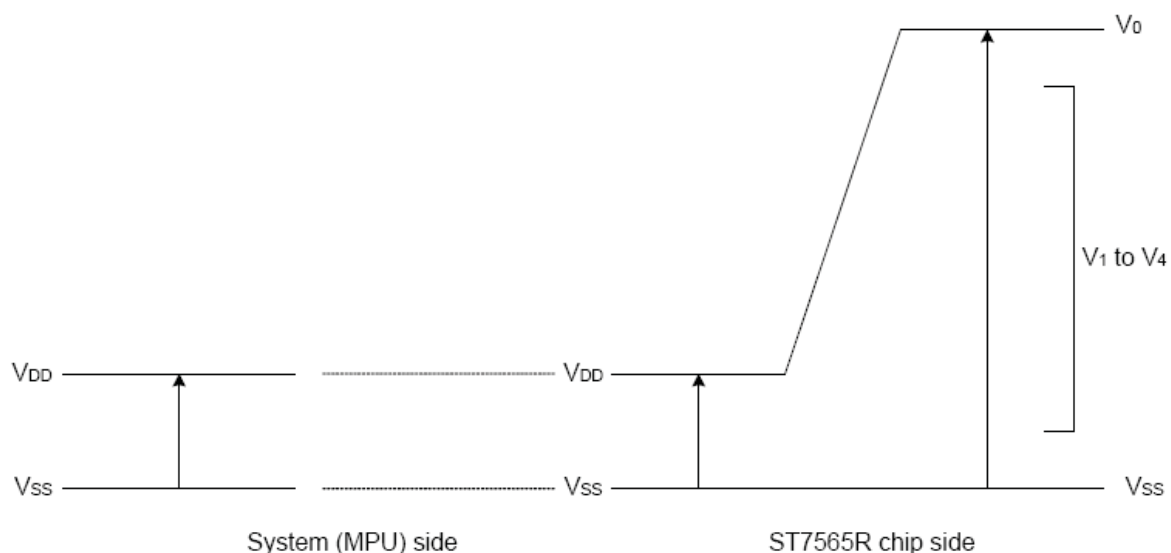

Figure 30

Notes and Cautions

1. The VDD2, V0 to V4 and VOUT are relative to the $V_{SS} = 0V$ reference.
2. Insure that the voltage levels of V1, V2, V3, and V4 are always such that $V_{out} \geq V_0 \geq V_1 \geq V_2 \geq V_3 \geq V_4$.
3. Permanent damage to the LSI may result if the LSI is used outside of the absolute maximum ratings. Moreover, it is recommended that in normal operation the chip be used at the electrical characteristic conditions, and use of the LSI outside of these conditions may not only result in malfunctions of the LSI, but may have a negative impact on the LSI reliability as well.

8. ELECTRICAL CHARACTERISTICS

Item	Symbol	Condition	Rating			Units	Applicable Pin		
			Min.	Typ.	Max.				
Operating Voltage (1)	V _{DD}		1.8	—	3.3	V	V _{SS} *1		
Operating Voltage (2)	V _{DD2}	(Relative to V _{SS})	2.4	—	3.3	V	V _{SS}		
High-level Input Voltage	V _{IHC}		0.8 x V _{DD}	—	V _{DD}	V	*3		
Low-level Input Voltage	V _{ILC}		V _{SS}	—	0.2 x V _{DD}	V	*3		
High-level Output Voltage	V _{OHC}	I _{OH} = -0.5 mA	0.8 x V _{DD}	—	V _{DD}	V	*4		
Low-level Output Voltage	V _{OLC}	I _{OL} = 0.5 mA	V _{SS}	—	0.2 x V _{DD}	V	*4		
Input leakage current	I _{LI}	V _{IN} = V _{DD} or V _{SS}	-1.0	—	1.0	μA	*5		
Output leakage current	I _{LO}	V _{IN} = V _{DD} or V _{SS}	-3.0	—	3.0	μA	*6		
Liquid Crystal Driver ON Resistance	R _{ON}	T _a = 25°C (Relative To V _{DD})	V ₀ = 13.0 V	—	2.0	3.5	KΩ	SE _{Gn} COM _n *7	
		V ₀ = 8.0 V	—	3.2	5.4				
Static Consumption Current	I _{SSQ}	V ₀ = 13.0 V (Relative To V _{DD})	—	0.01	2	μA	V _{DD} , V _{DD2}		
Output Leakage Current	I _{sq}		—	0.01	10	μA	V ₀		
Input Terminal Capacitance	C _{IN}	T _a = 25°C, f = 1 MHz	—	5.0	8.0	pF			
Oscillator Frequency	Internal Oscillator	f _{OSC}	1/65 duty 1/33 duty	T _a = 25°C	17	20	24	kHz	*8
	External Input	f _{CL}			17	20	24	kHz	CL
	Internal Oscillator	f _{OSC}	1/49 duty 1/53 duty 1/55 duty	T _a = 25°C	25	30	35	kHz	*8
	External Input	f _{CL}			25	30	35	kHz	CL

Item	Symbol	Condition	Rating			Units	Applicable Pin	
			Min.	Typ.	Max.			
Internal Power	Input voltage	V _{DD2}	(Relative To V _{SS})	2.4	—	3.3	V	V _{SS}
	Supply Step-up output voltage Circuit	V _{OUT}	(Relative To V _{SS})	—	—	13.5	V	V _{OUT}
	Voltage regulator Circuit Operating Voltage	V _{OUT}	(Relative To V _{SS})	6.0	—	13.5	V	V _{OUT}
	Voltage Follower Circuit Operating Voltage	V ₀	(Relative To V _{SS})	4.0	—	13.5	V	V ₀ * 9
	Base Voltage	V _{RS}	T _a = 25°C, (Relative To V _{SS}) -0.05%/°C	2.07	2.10	2.13	V	*10

9. TIMING CHARACTERISTICS

System Bus Read/Write Characteristics 1 (For the 8080 Series MPU)

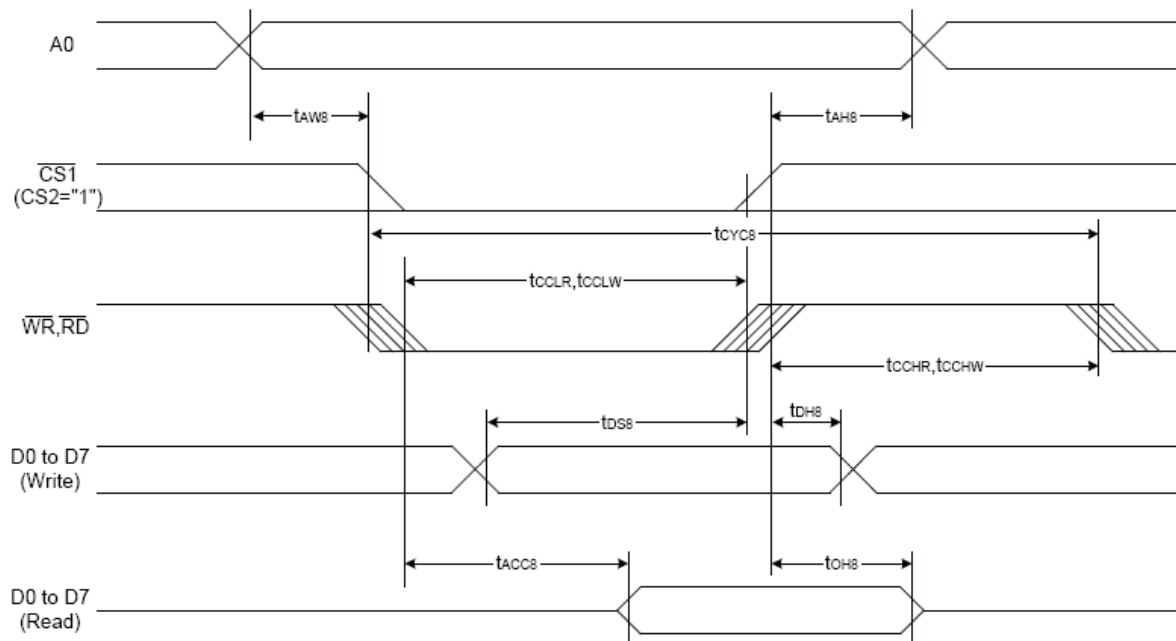

(VDD = 3.3V, Ta = -30 to 85°C)

Item	Signal	Symbol	Condition	Rating		Units
				Min.	Max.	
Address hold time	A0	tAHS		0	—	Ns
Address setup time		tAWS		0	—	
System cycle time		tCYC8		240	—	
Enable L pulse width (WRITE)	WR	tCCLW		80	—	
Enable H pulse width (WRITE)		tCCHW		80	—	
Enable L pulse width (READ)	RD	tCCLR		140	—	
Enable H pulse width (READ)		tCCHR		80	—	
WRITE Data setup time	D0 to D7	tDS8		40	—	
WRITE Address hold time		tDH8		0	—	
READ access time		tACC8	CL = 100 pF	—	70	
READ Output disable time		tOH8	CL = 100 pF	5	50	

System Bus Read/Write Characteristics 2 (For the 6800 Series MPU)

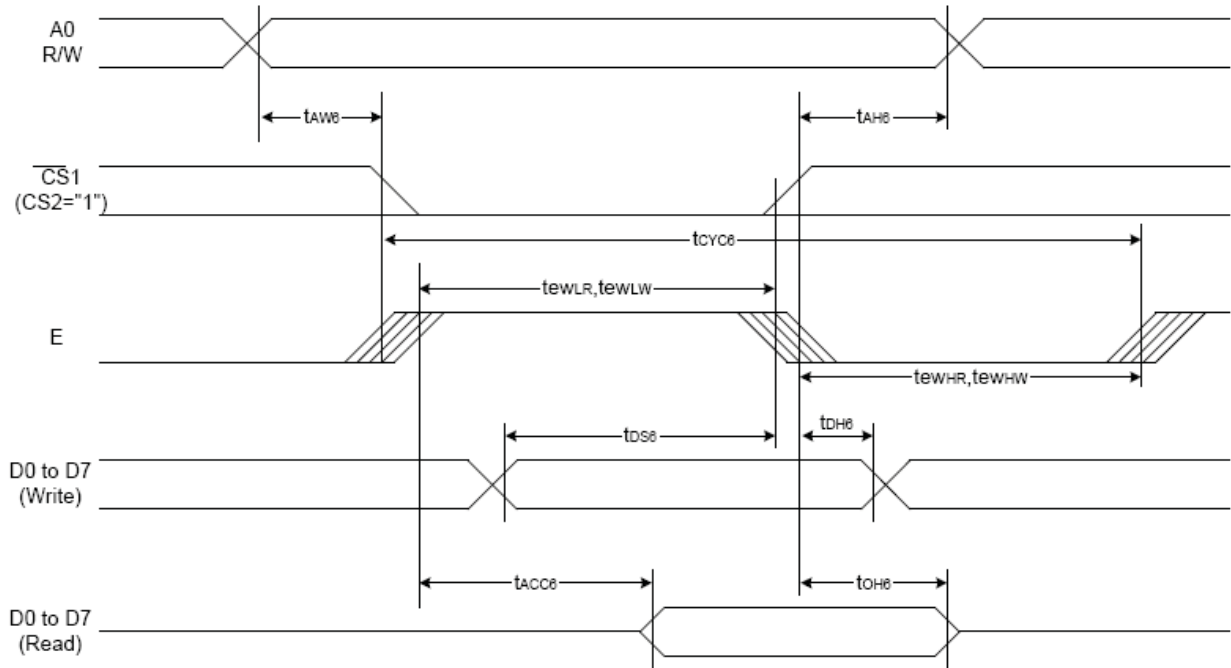

(VDD = 3.3V, Ta = -30 to 85°C)

Item	Signal	Symbol	Condition	Rating		Units
				Min.	Max.	
Address hold time	A0	tAH6		0	—	ns
Address setup time		tAW6		0	—	
System cycle time		tCYC6		240	—	
Enable L pulse width (WRITE)	WR	tEWLW		80	—	
Enable H pulse width (WRITE)		tEWHW		80	—	
Enable L pulse width (READ)	RD	tEHLR		80	—	
Enable H pulse width (READ)		tEWHR		140	—	
WRITE Data setup time	D0 to D7	tDS6		40	—	
WRITE Address hold time		tDH6		0	—	
READ access time		tACC6	CL = 100 pF	—	70	
READ Output disable time		tOH6	CL = 100 pF	5	50	

The 4-line SPI Interface

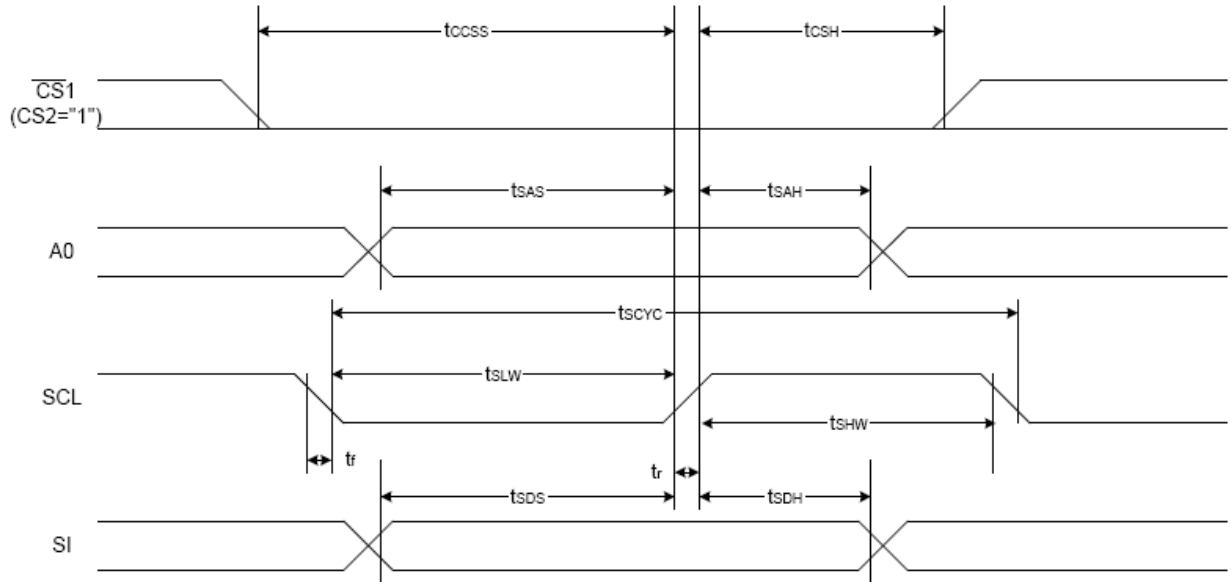

(VDD = 3.3V, Ta = -30 to 85°C)

Item	Signal	Symbol	Condition	Rating		Units
				Min.	Max.	
4-line SPI Clock Period	SCL	T_{scyc}		50	—	ns
SCL "H" pulse width		T_{shw}		25	—	
SCL "L" pulse width		T_{slw}		25	—	
Address setup time	A0	T_{sas}		20	—	
Address hold time		T_{sah}		10	—	
Data setup time	SI	T_{sds}		20	—	
Data hold time		T_{sdh}		10	—	
CS-SCL time	CS	T_{css}		20	—	
CS-SCL time		T_{csh}		40	—	

10. Reset Timing

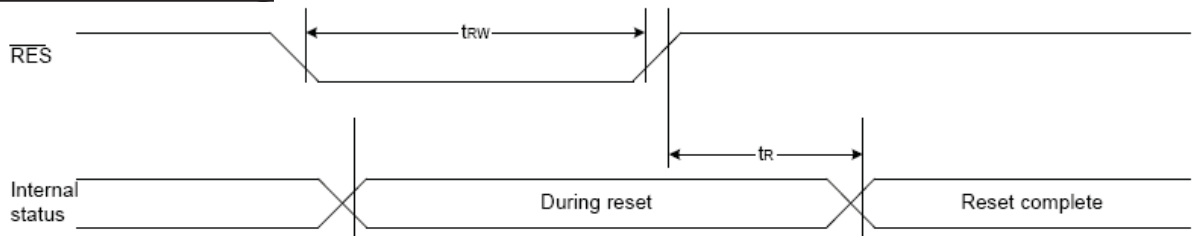

(VDD = 3.3V, Ta = -30 to 85°C)

Item	Signal	Symbol	Condition	Rating			Units
				Min.	Typ.	Max.	
Reset time		t_r		—	—	1.0	us
Reset "L" pulse width	\overline{RES}	t_{rw}		1.0	—	—	us

11. CONTROL AND DISPLAY INSTRUCTION

Command	Command Code										Function		
	A0	/RD	/WR	D7	D6	D5	D4	D3	D2	D1		D0	
(1) Display ON/OFF	0	1	0	1	0	1	0	1	1	1	0	1	LCD display ON/OFF 0: OFF, 1: ON
(2) Display start line set	0	1	0	0	1	Display start address						Sets the display RAM display start line address	
(3) Page address set	0	1	0	1	0	1	1	Page address				Sets the display RAM page address	
(4) Column address set upper bit Column address set lower bit	0	1	0	0	0	0	1	Most significant column address				Sets the most significant 4 bits of the display RAM column address.	
				0	0	0	0	Least significant column address				Sets the least significant 4 bits of the display RAM column address.	
(5) Status read	0	0	1	Status				0	0	0	0	Reads the status data	
(6) Display data write	1	1	0	Write data								Writes to the display RAM	
(7) Display data read	1	0	1	Read data								Reads from the display RAM	
(8) ADC select	0	1	0	1	0	1	0	0	0	0	0	1	Sets the display RAM address SEG output correspondence 0: normal, 1: reverse
(9) Display normal/reverse	0	1	0	1	0	1	0	0	1	1	0	1	Sets the LCD display normal/ reverse 0: normal, 1: reverse
(10) Display all points ON/OFF	0	1	0	1	0	1	0	0	1	0	0	1	Display all points 0: normal display 1: all points ON
(11) LCD bias set	0	1	0	1	0	1	0	0	0	1	0	1	Sets the LCD drive voltage bias ratio 0: 1/9 bias, 1: 1/7 bias (ST7565R)
(12) Read/modify/write	0	1	0	1	1	1	0	0	0	0	0	0	Column address increment At write: +1 At read: 0
(13) End	0	1	0	1	1	1	0	1	1	1	0	0	Clear read/modify/write
(14) Reset	0	1	0	1	1	1	0	0	0	1	0	0	Internal reset
(15) Common output mode select	0	1	0	1	1	0	0	0	*	*	*	*	Select COM output scan direction 0: normal direction 1: reverse direction
(16) Power control set	0	1	0	0	0	1	0	1	Operating mode			Select internal power supply operating mode	
(17) V ₀ voltage regulator internal resistor ratio set	0	1	0	0	0	1	0	0	Resistor ratio			Select internal resistor ratio(R _b /R _a) mode	
(18) Electronic volume mode set Electronic volume register set	0	1	0	1	0	0	0	0	0	0	0	1	Set the V ₀ output voltage electronic volume register
				0	0	Electronic volume value							
(19) Static indicator ON/OFF Static indicator register set	0	1	0	1	0	1	0	1	1	0	0	1	0: OFF, 1: ON Set the flashing mode
				0	0	0	0	0	0	0	0	0	Mode
(20) Booster ratio set	0	1	0	1	1	1	1	1	0	0	0	0	select booster ratio 00: 2x,3x,4x 01: 5x 11: 6x
				0	0	0	0	0	0	0	0	0	step-up value
(21) Power save	0	1	0									Display OFF and display all points ON compound command	
(22) NOP	0	1	0	1	1	1	0	0	0	1	1	1	Command for non-operation
(23) Test	0	1	0	1	1	1	1	*	*	*	*	*	Command for IC test. Do not use this command

12. BACK LIGHT CHARACTERISTICS

LCD Module with Side LED Backlight ELECTRICAL RATINGS

Ta = 25°C

Item	Symbol	Condition	Min	Typ	Max	Unit
Forward Voltage	VF	IF=60mA	2.9	3.1	3.3	V
Reverse Current	IR	VR=0.8V	---	15	---	mA
Luminance(without LCD)	Lv	IF=60mA	420	500	---	Cd/m ²
Color coordinate(without LCD)	λp	IF=60mA	X=0.26 Y=0.27	---	X=0.30 Y=0.31	
Color	white					

Note:

when the temperature exceed 25°C, the approved current decrease rate for Backlight change as the temperature increase is: -0.36mA/°C (below 25°C, the current refer to constant, which would not change with temperature).

13. ELECTRO-OPTICAL CHARACTERISTICS

(VDD=3.0V, Ta = 25°C)

Item	Symbol	Condition	Min	Typ	Max	Unit
Operating Voltage for LCD	Vop	Ta = -20°C	9.2	9.5	9.8	V
		Ta = 25°C	8.7	9.0	9.2	
		Ta = 70°C	8.2	8.5	8.8	
Response time	Tr	Ta = 25°C	---	200	400	ms
	Tf		---	250	500	ms
Contrast	Cr	Ta = 25°C	---	4.0	---	---
Viewing angle range	θ	Cr ≥ 2	-40	---	+40	deg
	φ		-40	---	+40	deg

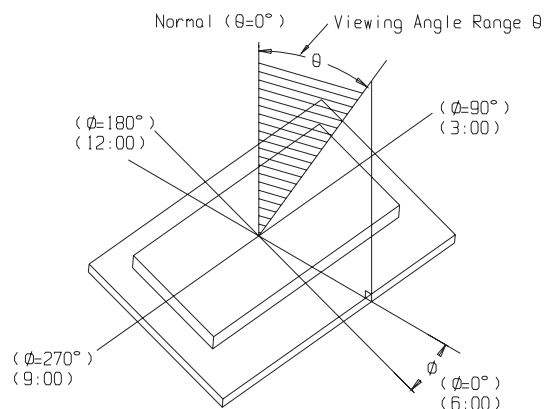
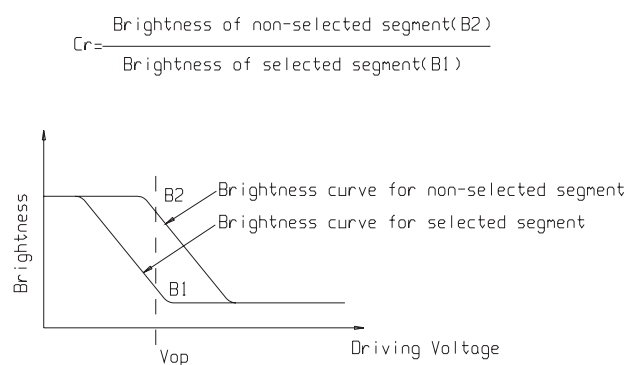

14. PRECAUTION FOR USING LCD/LCM

After reliability test, recovery time should be 24 hours minimum. Moreover, functions, performance and appearance shall be free from remarkable deterioration within 50,000 hours(average) under ordinary operating and storage conditions room temperature ($20\pm 8^{\circ}\text{C}$), normal humidity (below 65% RH), and in the area not exposed to direct sun light. Using LCM beyond these conditions will shorten the life time.

Precaution for using LCD/LCM

LCD/LCM is assembled and adjusted with a high degree of precision. Do not attempt to make any alteration or modification. The followings should be noted.

General Precautions:

1. LCD panel is made of glass. Avoid excessive mechanical shock or applying strong pressure onto the surface of display area.
2. The polarizer used on the display surface is easily scratched and damaged. Extreme care should be taken when handling. To clean dust or dirt off the display surface, wipe gently with cotton, or other soft material soaked with isopropyl alcohol, ethyl alcohol or trichlorotrifluoroethane, do not use water, ketone or aromatics and never scrub hard.
3. Do not tamper in any way with the tabs on the metal frame.
4. Do not make any modification on the PCB without consulting Orient Display.
5. When mounting a LCM, make sure that the PCB is not under any stress such as bending or twisting. Elastomer contacts are very delicate and missing pixels could result from slight dislocation of any of the elements.
6. Avoid pressing on the metal bezel, otherwise the elastomer connector could be deformed and lose contact, resulting in missing pixels and also cause rainbow on the display.
7. Be careful not to touch or swallow liquid crystal that might leak from a damaged cell. Any liquid crystal adheres to skin or clothes, wash it off immediately with soap and water.

Static Electricity Precautions:

1. CMOS-LSI is used for the module circuit; therefore operators should be grounded whenever he/she comes into contact with the module.
2. Do not touch any of the conductive parts such as the LSI pads; the copper leads on the PCB and the interface terminals with any parts of the human body.
3. Do not touch the connection terminals of the display with bare hand; it will cause disconnection or defective insulation of terminals.
4. The modules should be kept in anti-static bags or other containers resistant to static for storage.

5. Only properly grounded soldering irons should be used.
6. If an electric screwdriver is used, it should be grounded and shielded to prevent sparks.
7. The normal static prevention measures should be observed for work clothes and working benches.
8. Since dry air is inductive to static, a relative humidity of 50-60% is recommended.

Soldering Precautions:

1. Soldering should be performed only on the I/O terminals.
2. Use soldering irons with proper grounding and no leakage.
3. Soldering temperature: $350^{\circ}\text{C} \pm 10^{\circ}\text{C}$
4. Soldering time: 3 to 4 second.
5. Use eutectic solder with resin flux filling.
6. If flux is used, the LCD surface should be protected to avoid spattering flux.
7. Flux residue should be removed.

Operation Precautions:

1. The viewing angle can be adjusted by varying the LCD driving voltage V_o .
2. Since applied DC voltage causes electro-chemical reactions, which deteriorate the display, the applied pulse waveform should be a symmetric waveform such that no DC component remains. Be sure to use the specified operating voltage.
3. Driving voltage should be kept within specified range; excess voltage will shorten display life.
4. Response time increases with decrease in temperature.
5. Display color may be affected at temperatures above its operational range.
6. Keep the temperature within the specified range usage and storage. Excessive temperature and humidity could cause polarization degradation, polarizer peel-off or generate bubbles.
7. For long-term storage over 40°C is required, the relative humidity should be kept below 60%, and avoid direct sunlight.

Limited Warranty

Orient Display LCDs and modules are not consumer products, but may be incorporated by Orient Display's customers into consumer products or components thereof, Orient Display does not warrant that its LCDs and components are fit for any such particular purpose.

1. The liability of Orient Display is limited to repair or replacement on the terms set forth below. be responsible for any subsequent or consequential events or injury or damage to any personnel Orient Display will not or user including third party personnel and/or user. Unless otherwise agreed in writing between Orient Display and the customer, Orient Display will only replace or repair any of its LCD which is found defective electrically or visually when inspected in accordance with Orient Display general LCD inspection standard. (Copies available on request)
2. No warranty can be granted if any of the precautions state in handling liquid crystal display above has been disregarded. Broken glass, scratches on polarizer mechanical damages as well as defects that are caused accelerated environment tests are excluded from warranty.
3. In returning the LCD/LCM, they must be properly packaged; there should be detailed description of the failures or defect.

15. LCM TEST CRITERIA

1. Objective

The criteria is applied for consolidating the LCM quality standard between Orient Display and customer in finished products acceptance inspection and shipment, to guarantee the products quality to meet with customer's demand.

2. Scope

2.1 This criteria is applicable to all the LCM products produced by Orient Display.

3. Inspection equipment

Function Tester、 Vernier Calipers、 Microscope、 Magnifier、 ESD Wrist Strap、 Finger Cover 、 Labels、 High-Low Temperature Oven、 Refrigerator、 Constant Voltage Power Supply (DC), Desk Lamp, etc.

4. Sampling Plan and Reference Standard

4.1.1 According to GB/T 2828.1---2003/ISO2859-1:1999, single sampling under normal inspection, general inspection level II.

Item of Inspection	Times of Sampling	AQL Judgment
Cosmetic	II Single Sampling	MA=0.4 MI=1.5
Mechanical	N=3	C=0
Functional	II Single Sampling	MA=0.4 MI=1.5

4.1.2 GB/T 2828.1---2003/ISO2859-1:1999 Counting and sampling procedures and sampling table for Batch-to-Batch Inspection.

4.1.3 GB/T 1619.96 Test method for TN LCD.

4.1.4 GB/T 12848.91 General Specification for STN LCD.

4.1.5 GB2421-89 Basic Environmental Test Procedures for Electrical and Electronic Products

4.1.6 IPC-A-610C Acceptance Condition for Electrical Assemblies.

5. Inspection Condition and Inspection Reference

5.1 The ambient temperature and humidity are $25 \pm 5^{\circ}\text{C}$ and $45 \pm 20\%\text{RH}$ respectively, and the ambient luminance should be more than $300\text{cd}/\text{cm}^2$. The distance between inspector's eyes and the LCD panel should be 30cm away. Normally we inspect products with reflected light, when we inspect the LCD produces with backlight turned on, the ambient luminance should be less than $100\text{cd}/\text{cm}^2$.

5.2 The LCD should be test with 45° both left and right side, $0-45^{\circ}$ both upside

and downside (if for STN product, -20-55° is needed) .

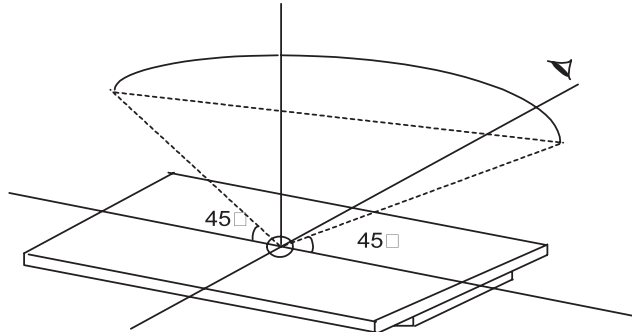

5.3 Definition of VA

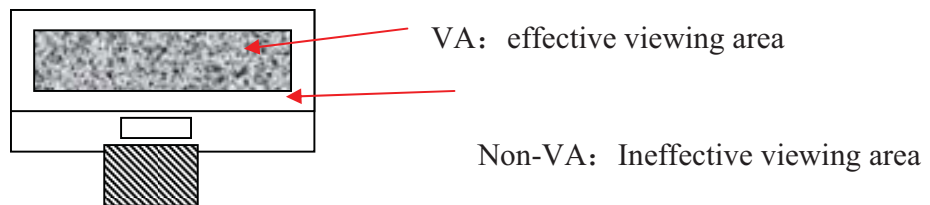

5.4 Inspection with viewed eyes (not including defect size measure by magnifiers) .

5.5 Electrical property

Inspect with the test jig to meet with the requirement indicated in the approved documents, including the pattern design and the display performance.

5.5.1 Testing voltage (V)

5.5.1.1 According to the inspection of test jig and production specification the test voltage setting is $V_{op} \pm 0.3V$ when the V_{op} is under 9.0V, and $V_{op} \pm 3\%V_{op}$ when the V_{op} is above 9.0V.

5.5.1.2 As per the product with the fixed voltage the test voltage setting is same as V_{op} and keeps the constant voltage through the internal circuit. And the limited sample on the voltage range is needed if necessary.



5.5.2 Current Consumption (I) : refer to product document and approval drawing to confirm it.

6. Inspection Item and Acceptance Standard

6.1 Outer dimension: For the outer dimension and the sizes which could influence the assembly at the customer's side, it should be in accordance to the approval drawing, and it belongs to the major defect.

6.2 Functional Test:

No.	Item	Description	MAJ	MIN	Accept
-----	------	-------------	-----	-----	--------

					standard
6.2.1	Missing Segment	Any missing segment caused by an open circuit; Any missing COM, pattern, dot or segment caused by an open circuit or poor crossover contact 	✓		Rejected
6.2.3	No display/no action	No segment is displayed when the product is connected correctly.	✓		Rejected
6.2.4	Display error/abnormal	The display pattern and display order is not as required under the normal scanning procedure.	✓		Rejected
6.2.5	Viewing angle wrong	The direction with the best display of patterns should be as customer required (or refer to the approval samples)	✓		Rejected
6.2.6	Display dim/dark	The contrast of LCD is too dark or too dim under normal operation	✓		Beyond the voltage tolerance, Rejected
6.2.7	Slow response	Response of some segments is different with others when turned on or off the LCD	✓		Rejected
6.2.8	Extra segment	Display of wiring, or extra pattern, caused by wrong alignment or insufficient corrosion..		✓	refer to spot/line standard
6.2.9	Dim segment	Under the normal voltage, the contrast of segment are uneven		✓	Reject or refer to samples
6.2.10	PI black/white spot	Partial black and white spot are visible while changing display content due to the PI layer defective		✓	refer to the spot/line criteria for the visible spots when display image stopped, others O
6.2.11	pinhole/white spot	The phenomena of missing patterns when turned on caused by missing of ITO fragment.  $d = (X+Y)/2$		✓	refer to spot/line standard

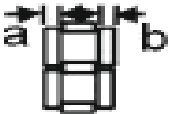
6.2.12	Pattern distortion	Width of pattern displayed is wider , narrower or deformed from the specifications caused by wrong alignment, i.e. extra heave or missing: $ Ia-Ib \leq 1/4W$ (W is the normal width)		✓	Acceptable $ Ia-Ib > 1/4W$, rejected
					
6.2.13	High current	the current is bigger than regulated value.		✓	Rejected

6.3 LCD Visual Defect

6.3.1 Dot defect(defined within VA, out of VA spots not accounted)

Defect item	Average diameter (d)	Accept numbers	MAJ	MIN
Spot defect (black spot, foreign material, nick, scratches, LC defect)	$d \leq 0.2$	3		✓
	$0.2 < d \leq 0.25$	2		
	$0.25 < d \leq 0.30$	1		

6.3.2 Line defect(defined within VA, out of VA spots not accounted)

Defective item	length(L)	width(W)	Accept numbers	MAJ	MIN
line defect (scratch, liner foreign material) 	≤ 5.0	≤ 0.02	3		✓
	≤ 3.0	≤ 0.03	3		
	≤ 3.0	≤ 0.05	1		

note: 1. If the width is bigger than 0.1mm, it can be treated as spot defect.

6.3.3 Polarizer Air Bubble (defined within VA, out of VA spots not accounted)

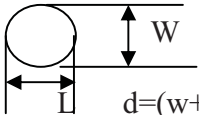
Defective item	Average diameter (d)	Accept numbers	MAJ	MIN
polarizer Air Bubble, Concave-Convex Dot 	$d \leq 0.3$	3		✓
	$0.3 < d \leq 0.5$	2		
	$0.5 < d \leq 0.8$	1		

6.3.4 Damaged(For the products with LCD edge expose to outside without mental frame, including products in COG, with H/S or assembled with backlight)

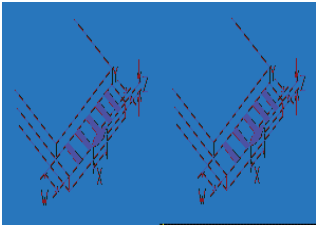
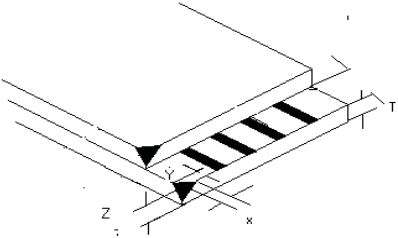
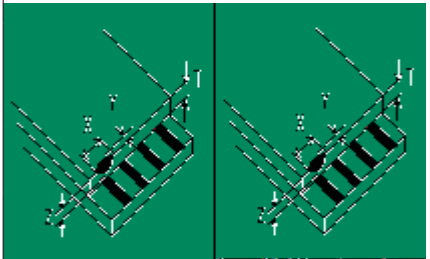
No.	Item	Acceptance Standard	MAJ	MIN	
6.3.4.1	Chip on lead 	(mm)		√	
		X			$\leq 1/8L$
		Y			$\leq 1/3W$
		Z			$\leq 1/2t$
		Accept number			2
When $Y \leq 0.2\text{mm}$, neglect the length of X, chip on the side without lead, and not perforated, when $X \leq 1/10L$, $Y \leq 1/2W$ max, accept.					
6.3.4.2	chip on corner(ITO lead) 	(mm)	MAJ	MIN	
		X	Not enter into frame epoxy and touch the lead	√	
		Y			
		Z	$\leq t$		
		Accept numbers	2		
Chips on corner refer to 6.3.4.3 and must be out of the frame epoxy. If chips on lead, refer to 6.3.4.1					
6.3.4.3	Chip on sealed area (outer chip) 	(mm)	MAJ	MIN	
		X	$\leq 1/8 L$	√	
		Y	$\leq 1/2H$		
		z	$\leq 1/2t$		
		Accept numbers	2		
The standard for inner chip on sealed area is same as the standard for outer. If chip on the opposite side of ITO lead, the value Y refer to 6.3.4.1 for the chip on the side without lead.					
note: t---glass thickness, L---length, H---The distance between the LCD edge to the inner of LCD frame epoxy. W—The width of ITO lead					

6.3.5 Others

No.	Item	Description	MAJ	MIN	Accept standard
6.3.5.1	Newton/ B/G color uniformity	There exists more than one color on one product or same batch.		√	Reject or refer to limited sample

	not good				
6.3.5.2	Leakage(LC)	/	√		Rejected
6.3.5.3	No protective film	/		√	Rejected

6.4 Backlight components

No.	Item	Description	MAJ	MIN	Accept standard
6.4.1	Backlight not work, wrong color	/	√		Rejected
6.4.2	Color deviation	Turn backlight, the color differ from the sample, do not match the drawing after testing		√	Refer to sample and drawing
6.4.3	Brightness deviation	Turn on backlight, the brightness is differ from the sample, or do not match the drawing after testing, or over $\pm 30\%$ compare with sample if drawing not specified.		√	Refer to sample and drawing
6.4.4	Uneven brightness	Turn on the backlight, the brightness is uneven on the same LED and beyond the specification of drawing.		√	Refer to sample and drawing
6.4.5	Spot/line scratch	There is stain, scratches on backlight when turn on.		√	Refer to 6.3.1/6.3.2

6.5 Mental frame

No.	Item	Description	MAJ	MIN	Accept standard
6.5.1	material/surface	Mental frame/surface approach inconsistent with specification.	√		Rejected
6.5.2	Twist not qualified/without twisting	Twist method/direction wrong, not twist as required	√		Rejected
6.5.3	Oxidized steak, paint stripped, color changed, dented mark, scratches	1.Oxidized steak on the surface of the metal frame;2. front surface paint scratch to substrate, the stripped spot $\leq 0.8\text{mm}$ and exceed 3 areas;3.line defect in length $\leq 5.0\text{mm}$ and width $\leq 0.05\text{mm}$ exceed 2 areas, front dent, bubble and side surface have paint stripping to substrate $\leq 1.0\text{mm}$ exceed 3 areas, line defect in width		√	Rejected

		≤0.05mm exceed 3 areas.			
6.5.4	Burred	Burr is too long, enter into viewing area		√	Rejected

6.6 PCB/COB

No.	Item	Description	MAJ	MIN	Accept standard
6.6.1	Epoxy Cover Improper	<ol style="list-style-type: none"> 1. The Pad within the round white mark is exposed to outside. 2. The height of epoxy covers beyond document /drawing specification. 3. The epoxy should be covered within the white round mark and the maximum overage is 2mm more than the radius of white mark. 4. Clear liner mark on COB surface or pinhole that it is possible to penetrate through the epoxy to chip. 5. The pinhole diameter over 0.25mm or other material on COB surface. 		√	Rejected
6.6.2	PCB cosmetic defect	<ol style="list-style-type: none"> 1. PCB pad surface can not be oxidized or contaminated. 2. PCB can not appear bubbles after through the reflow oven. 3. Copper lead due to the PCB green oil drop or scratches. If repaired by adding the green oil, circuit diameter Φ can not over 1.3mm, other diameter Φ can not over 2.6mm, total less than 10 areas. Otherwise reject. 		√	Rejected
6.6.3	Components error	<ol style="list-style-type: none"> 1. PCB components inconsistent with drawing. Wrong components, more or less pa, polar reverse (The bias circuit of LCD voltage or BL limit current value adjustment is not controlled if not special specified.) 2. The JUMP short of PCB should be consistent of the mechanical drawing. 3. The components is specially required by 	√		Rejected

		the customers and specified in mechanical drawing / technical documents, the components specification should be conformed to technique demand. Otherwise rejected			
--	--	---	--	--	--

6.7 SMT part (Refer to IPC-A-610C if not specified)

No.	Item	Description	MAJ	MIN	Accept standard
6.7.1	Soldering defect	Cold soldering, false solder, missing solder, tin crack, tin un-dissolved happened with soldering.		√	Rejected
6.7.2	Solder ball/splash	Solder ball/tin dross drop lead to solder short.		√	Rejected
6.7.3	DIP parts	DIP parts, keypad, connection appear floating and tilted.		√	Rejected
6.7.4	Spot weld shape	The spot weld should be inner dent, can not form to cover solder or less solder or icicle, otherwise reject		√	Rejected
6.7.5	Component foot exposed	For the DIP type components, after soldered, 0.5~2mm component foot must be remained, and should not damage the solder surface nor fully covered the component foot. Otherwise rejected.		√	Rejected
6.7.6	Appearance poor	After soldering, the solder residues appear brown or black. PCB solder spot remained white mist residues after clean.		√	Rejected

6.8 Heating pressure part (including H/S, FPC, etc.)

No.	Item	Description	MAJ	MIN	Accept standard
6.8.1	Out of specification		√		Rejected
6.8.2	Size/position	The size of heating material should be within the specification of the drawing, the contact area of conducted material should be attached more than 1/2 of the body (ITO, PDA, etc)		√	Acceptable
6.8.3	Heat pressure dirty	The obstacle existed in non-conductive heating area and not lead to short, or existed in conductive area but the obstacle is less than 50% of pressure area, it is acceptable.		√	Acceptable

6.8.4	Folding defect			√	Refer to limited sample
-------	----------------	--	--	---	-------------------------

6.9 Connector and other parts

No.	Item	Description	MAJ	MIN	Accept standard
6.9.1	Specification improper	The specification of connector and other components do not conform to the drawing as required.	√		Rejected
6.9.2	Position and order	Solder position and Pin 1 should be consistent with the drawing.		√	Rejected
6.9.3	Cosmetic	1. The body of outer component and the PIN has flux. 2. The deformation bigger of PIN connector is bigger than 1/2 of PIN width.		√	Rejected

6.10 General cosmetic

No.	Item	Description	MAJ	MIN	Accept standard
6.10.1	Connection material	Copper lead on FPC pad or the pin terminal of H/S, FFC and damaged. FPC,FFC, COF,H/S connected material curved (except for original) . FPC、PCB pad is bigger than 1PIN width. FPC/FFC material segment, crease exceed the specification.		√	Rejected
6.10.2	Stiffing type defect	Stiffening tape is not covered or fully covered the product's circuit needs to be protected. (Like H/S, FFC, FPC) or cover to the output pin.		√	Rejected
6.10.3	Visual dirty	Dirty on surface of finished products, residual glue, solder spatter or solder ball remain on non-soldered area of PCB/COB. The defective mark or label on product does not remove.		√	Rejected
6.10.4	Assembly black spot	The spot or black dots found after assembly the products with backlight or diffuser.		√	Refer to 6.3.1
6.10.5	Product mark	Part number and batch mark is not conformed with the technical requirement and position, not clear or without mark.		√	Rejected
6.10.6	Inner packing	Packing is inconsistent with requirement, short or over load, Packing is inconsistent with shipment mark/ order demand.		√	Rejected

7. Reliability test

Test item	Condition	Time(hrs)	Accept standard
High Temp Storage	80°C	120	No abnormalities in functions and appearance
High Temp Operating	70°C	120	
Low Temp Storage	-30°C	120	
Low Temp Operating	-20°C	120	
Temp& Humidity Test	40°C/90%RH	120	
Temp Shock	-20°C ← 25°C → +70°C (30 min ← 5 min → 30min)	10 cycles	

Note: ①The customer should inform the special requirements on the reliability test to Orient Display when starting the project.

②For high/low temperature test under both storage and operating condition, the temperature is referrer to the product specification.

③For temperature test $\pm 5^{\circ}\text{C}$ deviation could be accepted.

8. Packing

8.1 Product packing must meet the requirement of packing design. The label should be qualified by QA department and it includes the Item No., specification sheet, quantity and production date. Incomplete or mistake is regarded as not qualified.

8.2 When the safety of the packing exist the problems, including shock resistance, moisture resistance, anti-ESD and press resistance, it is regarded as not qualified.

8.3 When customer has special requirement on packing, which is confirmed and accepted by Orient Display , inspect and release the products as customer required.

8.4 For RoHS or non-RoHS products it should be distinguished with obvious label. Currently we adopt the “RoHS” label for all the products meet the RoHS compliance, or using the labels / marks as the customer required.

9. Others

9.1 For unregulated and compromised items, reference shall be taken to mutual agreements and limit samples.